

SUPERSEDED

Technical Specification

**Transport and Main Roads Specifications
MRTS45 Road Surface Delineation**

March 2020

Copyright

© The State of Queensland (Department of Transport and Main Roads) 2020.

Licence



This work is licensed by the State of Queensland (Department of Transport and Main Roads) under a Creative Commons Attribution (CC BY) 4.0 International licence.

CC BY licence summary statement

In essence, you are free to copy, communicate and adapt this work, as long as you attribute the work to the State of Queensland (Department of Transport and Main Roads). To view a copy of this licence, visit: <https://creativecommons.org/licenses/by/4.0/>

Translating and interpreting assistance



The Queensland Government is committed to providing accessible services to Queenslanders from all cultural and linguistic backgrounds. If you have difficulty understanding this publication and need a translator, please call the Translating and Interpreting Service (TIS National) on 13 14 50 and ask them to telephone the Queensland Department of Transport and Main Roads on 13 74 68.

Disclaimer

While every care has been taken in preparing this publication, the State of Queensland accepts no responsibility for decisions or actions taken as a result of any data, information, statement or advice, expressed or implied, contained within. To the best of our knowledge, the content was correct at the time of publishing.

Feedback

Please send your feedback regarding this document to: tmr.techdocs@tmr.qld.gov.au

Contents

- 1 Introduction1**
- 2 Definition of terms1**
- 3 Referenced documents2**
- 4 Test methods.....2**
- 5 Quality system requirements3**
 - 5.1 Hold Points..... 3
 - 5.2 Construction procedures..... 3
 - 5.3 Testing frequencies 3
- 6 Material requirements3**
 - 6.1 Pavement markings 3
 - 6.1.1 *Material and performance criteria*.....3
 - 6.1.2 *Paint*3
 - 6.1.3 *Reflective glass beads*4
 - 6.1.4 *Skid resistance for transverse line marking*4
 - 6.1.5 *Thermoplastic materials*4
 - 6.1.6 *Cold applied plastic materials*.....5
 - 6.2 Raised retroreflective pavement markers 5
 - 6.3 Non-retroreflective raised pavement markers 5
 - 6.4 Temporary raised pavement markers..... 5
 - 6.5 Pavement bars 5
 - 6.6 Adhesives for raised pavement markers 5
- 7 Installation of pavement markings.....5**
 - 7.1 Setting out..... 5
 - 7.2 Weather conditions 6
 - 7.3 Surface preparation 6
 - 7.4 Spotting..... 7
 - 7.4.1 *General*.....7
 - 7.4.2 *Longitudinal lines*.....7
 - 7.4.3 *Transverse markings*.....7
 - 7.5 Application of pavement markings..... 7
 - 7.5.1 *Procedure*7
 - 7.5.2 *Paint*7
 - 7.5.3 *Thermoplastic material*9
 - 7.5.4 *Cold applied plastic* 10
 - 7.6 Raised pavement markers..... 11
 - 7.6.1 *Application of retroreflective pavement markers* 11
 - 7.6.2 *Application of non-reflective pavement markers* 11
 - 7.7 Audio tactile line marking..... 11
 - 7.7.1 *Application of audio tactile line marking* 11
 - 7.7.2 *Application on existing painted lines* 11
 - 7.7.3 *Placement and dimension of audio tactile line marking* 11
 - 7.7.4 *Gaps for cyclists* 12
 - 7.7.5 *Adjacent residences – noise considerations* 13
 - 7.7.6 *Luminance and retroreflectivity* 13
 - 7.8 Protection of the work 13

7.9	Tolerances	13
7.9.1	<i>Pavement markings</i>	13
7.9.2	<i>Audio tactile line marking</i>	14
7.9.3	<i>Raised pavement markers</i>	14
7.10	Removal of existing pavement markings.....	15
7.11	Wide centreline treatments	15
7.11.1	<i>Application of wide centreline treatments</i>	15
8	Installation of raised pavement markers and pavement bars	15
9	Compliance testing	16
9.1	General	16
9.2	Testing frequencies and number of tests	16
9.3	Geometrics.....	16
10	Supplementary requirements	16

SUPERSEDED

1 Introduction

This Technical Specification applies to the supply and installation of pavement markings, raised pavement markers and audio tactile line marking (ATLM). This Technical Specification does not apply to the supply and installation of coloured surfacings such as those used on cycle lanes, busways, coloured pavement markings and transit lanes, for use for township entry treatments or similar applications.

This Technical Specification shall be read in conjunction with MRTS01 *Introduction to Technical Specifications*, MRTS50 *Specific Quality System Requirements* and other Technical Specifications as appropriate.

This Technical Specification forms part of the *Transport and Main Roads Specifications Manual*.

Coloured pavement surfacings should be applied in accordance with best practice to ensure these treatments are durable and have adequate skid resistance. Until such time as a Technical Specification has been developed for these coloured pavement surfacings, Transport and Main Roads Supplementary Specification MRSS10B Colour Surfacings for Cycleways (MRSS10B) should be used.

For further advice or to obtain a copy of the Supplementary Specification MRSS10B, please contact the Principal Engineer (Asphalt and Surfacings) on (07) 3066 7726 from Pavement, Research and Innovation Unit.

2 Definition of terms

The terms used in this Technical Specification shall be as defined in Clause 2 of MRTS01 *Introduction to Technical Specifications*. Additional terms used in this Technical Specification shall be as defined in Table 2.

Table 2 – Definition of terms

Term	Definition
AADT	Annual Average Daily Traffic
ATLM	Audio tactile line marking
Longitudinal lines	Dividing, barrier, lane, edge and continuity lines and outline markings
MUTCD	Queensland <i>Manual of Uniform Traffic Control Devices</i>
Pavement markings	Longitudinal lines, transverse lines and pavement messages
Retroreflectivity	The value of reflected light measured in millicandellas per lux per m ² , using a retroreflectometer calibrated to a nationally recognised standard, using a 30 m geometry instrument
Transverse lines	Stop and give way lines, turn lines, markings at stop and give way signs, pedestrian crosswalk lines, diagonal and chevron markings, arrows, shapes, symbols, numerals, parking areas and kerb markings

3 Referenced documents

Table 3 lists documents referenced in this Technical Specification.

Table 3 – Referenced documents

Reference	Title
AS/NZS 1906.3	<i>Retroreflective materials and devices for road traffic control purposes, Part 3: Raised pavement markers (retroreflective and non-retroreflective)</i>
AS/NZS 2009	<i>Glass beads for pavement-marking materials</i>
AS 2700	<i>Colour standards for general purposes</i>
AS 3554	<i>Adhesives – Epoxy – For raised pavement marker installation</i>
AS 4049.2	<i>Paints and related materials – Pavement marking materials - Thermoplastic pavement marking materials – For use with surface applied glass beads</i>
AS 4049.3	<i>Paints and related materials – Pavement marking materials – Waterborne paint – For use with surface applied glass beads</i>
AS 4049.4	<i>Paints and related materials – Pavement marking materials – High performance pavement marking systems</i>
Australian Paint Approval Scheme – Specification AP-S0041/3	<i>Pavement marking paint, cold applied plastic</i>
Australian Paint Approval Scheme – Specification AP-S0041/4	<i>Pavement marking paint, thermoplastic</i>
Australian Paint Approval Scheme – Specification AP-S0041/5	<i>Pavement marking paint, water-borne</i>
Australian Paint Approval Scheme – Specification AP-S0042	<i>Glass beads for use in pavement marking paints</i>
MRSS10B	<i>Colour Surfacing for Cycleways</i>
MRTS01	<i>Introduction to Technical Specifications</i>
MRTS45	<i>Road Surface Delineation</i>
MRTS50	<i>Specific Quality System Requirements</i>
MUTCD	<i>Queensland Manual of Uniform Traffic Control Devices</i>
TN155	<i>Wide Centre Line Treatment – Interim Advice</i>
TRUM Volume 2 Part 5	<i>Traffic and Road Use Management Manual, Volume 2, Part 5 Road Safety for Rural and Remote Areas</i>

4 Test methods

Test methods are as specified throughout this Technical Specification.

5 Quality system requirements

5.1 Hold Points

General requirements for Hold Points are specified in Clause 5.2 of MRTS01 *Introduction to Technical Specifications*.

The Hold Points, applicable to this Technical Specification are summarised in Table 5.1. There are no Witness Points or Milestones defined.

Table 5.1 – Hold Points, Witness Points and Milestones

Clause	Hold Point	Witness Point	Milestone
7.3	1. Surface preparation		
7.4.1	2. Setting out of pavement markings		

5.2 Construction procedures

The Contractor shall prepare documented procedures for all construction processes as defined in Clause 5 of MRTS50 *Specific Quality System Requirements*.

Construction procedures which are required to be prepared by the Contractor and submitted to the Administrator in accordance with the quality system requirements of the Contract are listed in Table 5.2.

Table 5.2 – Construction procedures

Clause	Procedure
7.5	Application of pavement markings

5.3 Testing frequencies

The testing frequency requirements shall be in accordance with AS 4049.4 and may be varied as stated in Clause 1 of Annexure MRTS45.1. The Contractor shall measure the level of retroreflectivity using the procedure set out in AS 4049.4.

6 Material requirements

6.1 Pavement markings

6.1.1 Material and performance criteria

Longitudinal line marking, excluding ATLM, when applied, shall have a minimum retroreflectivity of 350 mcd/lux/m² measured up to 20 days of wear.

6.1.2 Paint

Paint shall be suitable for use on roads surfaced with a sprayed seal, hot and cold mixed asphalt and concrete.

Except where specifically shown otherwise on the design documents, paint shall be in accordance with the colour designation of AS 2700 as given in Table 6.1.2 following.

Table 6.1.2 – Paint colour designation

Colour	AS 2700 colour designation
White	Y35 Off White (or whiter)
Yellow	Y14 Golden Yellow

Paint used shall be waterborne road marking paint conforming to the requirements of AS 4049.3 and having approval under the Australian Paint Approval Scheme – Specification AP-S0041/5.

Coloured pavement surfacings should be applied in accordance with best practice to ensure that these treatments are durable and have adequate skid resistance. Until such time as a Technical Specification has been developed for these coloured pavement surfacings, Transport and Main Roads Supplementary Specification *Colour Surfacings for Cycleways* (MRSS10B) should be used.

For further advice or to obtain a copy of the Supplementary Specification MRSS10B, please contact the Principal Engineer (Asphalt and Surfacings) on (07) 3066 7726 from Pavement Research and Innovation Unit.

6.1.3 Reflective glass beads

Reflective glass beads shall be Type B, B-HR, C, D or D-HR glass beads as described in AS 2009. The type to be used shall be as stated in Clause 3 of Annexure MRTS45.1.

The glass beads shall comply with the requirements of AS 2009 and the Australian Paint Approval Scheme – Specification AP-S0042.

6.1.4 Skid resistance for transverse line marking

Transverse markings shall incorporate an anti-skid treatment and shall have a skid resistance as shown in Table 6.1.4 following. Application of the anti-skid treatment shall comply with the manufacturer's requirements.

Table 6.1.4 – Skid resistance level and test method

Material type	Skid resistance level (BPN) (under wet conditions)	Test method
Waterborne paint	45	AS 4049.4 Appendix J or APAS (Using Grip Tester)
Thermoplastic	45	AS 4049.2 Appendix L or APAS ((Using Grip Tester)
Cold applied plastic	45	AS 4049.2 Appendix L or APAS (Using Grip Tester)

The testing frequency requirements shall be in accordance with AS 4049.4 and may be varied as stated in Clause 1 of Annexure MRTS45.1. The Contractor shall measure the level of retroreflectivity using the procedure set out in AS 4049.4.

6.1.5 Thermoplastic materials

Thermoplastic materials shall comply with the requirements of AS 4049.2 and have approval under the Australian Paint Approval Scheme – Specification AP-S0041/4.

6.1.6 Cold applied plastic materials

Cold Applied Plastic materials shall comply with the requirements of AS 4049.4 and Clause 4 of Annexure MRTS45.1 and have approval under the Australian Paint Approval Scheme – Specification AP-S0041/3.

6.2 Raised retroreflective pavement markers

Raised retroreflective pavement markers shall comply with the requirements of AS 1906.3 and shall be Type A1 either uni-directional or bi-directional.

Bi-directional raised retroreflective pavement markers shall be white or yellow as shown on the Drawings. Uni-directional raised retroreflective pavement markers shall be white, red, green or yellow as shown on the Standard Drawings.

6.3 Non-retroreflective raised pavement markers

Non-retroreflective raised pavement markers shall comply with the requirements of AS 1906.3 and shall be Type B.

Non-retroreflective raised pavement markers shall be circular, approximately 100 mm in diameter, and 15 mm high. The colour shall be white.

6.4 Temporary raised pavement markers

Temporary raised pavement markers shall comply with the requirements of AS 1906.3.

6.5 Pavement bars

Pavement bars shall be manufactured in accordance with details shown on the design documents. Where not otherwise shown, pavement bars shall be manufactured from concrete and painted white.

6.6 Adhesives for raised pavement markers

The adhesive used to install raised pavement markers shall comply with the manufacturer's specification. If the manufacturer's specification is not available, the requirements of AS 3554 shall be complied with.

7 Installation of pavement markings

7.1 Setting out

The Contractor shall carry out all work necessary to establish satisfactory alignment of pavement markings, within the specified tolerances (see Table 7.9.3), using any device or method which will not damage the pavement nor conflict with other traffic control devices.

Prior to resealing or placement of an asphalt overlay, the Contractor shall take such measurements, prepare such drawings and establish such offset marks that will allow the existing pavement markings to be reinstalled following completion of the surface re-treatment.

Prior to spotting on reseals and asphalt overlay, the Contractor shall install a control line at 20 m intervals.

For new construction, the Contractor shall install a control line at 20 m intervals in accordance with the Standard Drawing requirements prior to spotting.

7.2 *Weather conditions*

Pavement markings shall not be applied when freshly applied pavement markings may become damaged by rain, fog or condensation before they have dried or set. Pavement surfaces shall be thoroughly dry immediately prior to the application of pavement markings.

Applying waterborne paint incorporating glass beads under the following conditions will achieve the best results:

- a) air temperature and pavement temperature $>15^{\circ}\text{C}$
- b) relative humidity $<70\%$
- c) air movement >10 km/h (reasonable air movement), and
- d) adequate protection of lines from traffic during the drying process.

Waterborne paint must not be applied when relative humidity is above 85% and when air or pavement temperatures are below 10°C .

Thermoplastic materials must be applied in accordance with the manufacturer's recommended application temperature. Application at the manufacturer's recommended temperature will assist in achieving the correct glass bead embedment depth, to aid bead retention and marking retroreflectivity or night-time visibility.

This is an important consideration especially when using the large diameter Type D or Type D-HR glass beads.

7.3 *Surface preparation*

The surface area to be marked must be dry and free of dirt, gravel, flaking pavement marking material and other loose or foreign material. The area around the marking must also be free of dirt, gravel and other loose or foreign material so that tracking of such material on to the new marking is avoided.

If any of these conditions is not met, the pavement marking work shall be delayed until the surface is fully dried or prepared as detailed following.

- a) Where the existing material is flaking or chipping, is of a type or is in such a condition that adhesion of the new material to the road surface cannot be guaranteed for the required life of the marking, obtain the agreement of the Principal to the proposed method of surface preparation and its extent.
- b) Where a pavement marking material is to be applied to a surface where it may be incompatible with the existing marking or surface, prepare the marking or surface suitably before applying the pavement marking material.
- c) Where a curing compound has been applied to a new rigid concrete pavement surface, remove the curing compound by physical abrasive means such as grinding or blasting, from the areas where the pavement marking material is to be applied.

In addition to these requirements, new bitumen sealed surfaces which are to receive pavement markings shall be free of volatile material and solvents. **Hold Point 1**

7.4 Spotting

7.4.1 General

Spotting shall consist of spots approximately 30 mm wide and 150 mm long painted on the pavement surface.

The Contractor shall obtain approval from the Administrator of the spotting prior to any application of pavement markings. **Hold Point 2**

7.4.2 Longitudinal lines

Spotting for longitudinal lines shall be carried out generally at 5 m intervals with 3 m intervals on curves of less than 50 m radius.

7.4.3 Transverse markings

Spotting for transverse markings shall be carried out as shown on the design documents.

7.5 Application of pavement markings

7.5.1 Procedure

The Contractor shall submit its procedure for application of pavement markings. The procedure shall include details of the materials, application rates, equipment and method, including manufacturer's recommendations, to be used when applying pavement markings.

7.5.2 Paint

7.5.2.1 Mixing

Mixing of paint shall be carried out strictly in accordance with the manufacturer's recommendations.

7.5.2.2 Application equipment

Mechanical means shall be used to apply painted pavement markings.

All equipment used in the application of pavement markings shall produce pavement markings of uniform quality which conform to the requirements of this standard.

The longitudinal line application machine shall be capable of accurately superimposing succeeding coats of paint upon the first coat and upon existing lines.

The longitudinal line application machine shall consist of a rubber-tyred vehicle which is manoeuvrable to the extent that straight lines can be followed, and normal curves can be painted in true arcs. The machine shall be capable of applying road marking paints and glass beads at the rates specified.

The longitudinal line application machine shall be equipped with the following:

- a) a positive acting cut-off device to prevent depositing paint in gaps of broken lines, and
- b) a glass bead dispenser located behind the paint applicator nozzle and which is controlled simultaneously with the paint applicator nozzle.

Where the configuration or location of a longitudinal line is such that the use of a longitudinal line application machine is unsuitable, road marking paint and glass beads may be applied by hand-sprayed means.

Stencils, boards and hand-spray equipment shall be used to paint transverse markings. Stencils shall conform to the dimensions shown on the design documents or in the Queensland *Manual of Uniform Traffic Control Devices*.

All road marking vehicles shall have been tested and calibrated to achieve the required rates of application of road marking materials.

7.5.2.3 Application of paint and glass beads to new pavement surface

All markings shall be of uniform thickness and intensity. Care shall be taken to avoid overspray on to the surrounding area.

Waterborne paint shall not be heated to a temperature greater than 65°C.

Two coats of paint and glass beads shall be applied on longitudinal lines to new surfaces.

Each coat of paint for any longitudinal line group, including glass beads, shall be applied in one pass of the longitudinal line application machine, regardless of the number, width, and pattern of the individual lines involved.

The first coat of paint shall be applied using Type B-HR glass beads. A second coat of paint shall be applied as directed by the Administrator, using glass beads as specified in Clause 2 of Annexure MRTS45.1.

The Contractor shall obtain approval from the Administrator prior to any application of the first coat of paint.

Glass beads shall be uniformly incorporated in all coats of paint concurrently with the application of the paint.

7.5.2.4 Application rates

The minimum application rates for the paint and glass beads shall be as specified in Table 7.5.2.4.

Table 7.5.2.4 – Application rates for paint and glass beads

Work type	Asphalt and 7 mm chip seal surface		Chip seal surfaces >7 mm seal	
	Wet paint application rate lit/m ²	Coverage (minimum per coat) g/m ²	Wet paint application rate lit/m ²	Coverage (minimum per coat) g/m ²
Longitudinal lines – first coat Type B (drop-on beads), B-HR	0.375 ± 0.025	>300	0.415 ± 0.025	>330
Longitudinal lines – second coat Type B (drop-on beads), B-HR	0.375 ± 0.025	>300	0.415 ± 0.025	>330
Longitudinal lines – repaint Type B (drop-on beads), B-HR	0.375 ± 0.025	>300	0.415 ± 0.025	>330
Longitudinal lines – second coat or repaint applying Type D, D-HR beads	0.500 ± 0.025	>500	0.550 ± 0.025	>550
Transverse lines – Type B (drop-on beads), B-HR	0.375 ± 0.025	>300		>330
Transverse lines – Type D, D-HR beads	0.500 ± 0.025	>400		>440

The combination application rates for skid resistance and glass beads shall not exceed the values specified previously and in Clause 6.1.4 unless specified by the manufacturer.

7.5.3 Thermoplastic material

7.5.3.1 Primer

If primer is required, a primer, of the type recommended by the manufacturer of the thermoplastic material, shall be applied to the surface immediately in advance of, but concurrent with, the application of thermoplastic material.

The primer shall be applied at the application rate recommended by the manufacturer and shall not be thinned.

7.5.3.2 Application of thermoplastic material

Thermoplastic material may be applied by screeding, spraying, extrusion or profiling or as preformed material.

Thermoplastic material shall be applied to the pavement at a temperature between 180°C–200°C unless a different temperature is recommended by the manufacturer.

The pavement surface to which thermoplastic material is applied shall be completely coated by the material and any voids in the pavement surface shall be filled.

7.5.3.3 Application rate

Thermoplastic material shall be applied at the minimum thickness specified in Table 7.5.3.3.

Table 7.5.3.3 – Thermoplastic application thickness

Location	Minimum application thickness (mm)
Longitudinal lines	2
Transverse markings	2

Glass beads shall be applied immediately to the surface of the molten thermoplastic material at a rate of not less than 120 g/m².

7.5.4 Cold applied plastic

7.5.4.1 Primer

If primer is required, a primer, of the type recommended by the manufacturer of the cold applied plastic material, shall be applied to the surface immediately in advance of, but concurrent with, the application of the cold applied plastic material. The primer shall be applied at the application rate recommended by the manufacturer and shall not be thinned.

7.5.4.2 Application

Cold Applied Plastic (CAP) shall be applied in accordance with the manufacturer's specifications. The applied dry film thickness of cold plastic laid shall not be less than 700 microns for longitudinal line marking and a minimum of 1 mm for transverse line marking. Where CAP is to be applied to a new surface, two coats of water-borne paint shall be applied to the surface prior to the application of CAP. Water-borne paint shall be applied in accordance with Clause 7.5.2.3. CAP shall be applied 28 – 90 days following the application of water-borne paint on a new surface.

Applying cold applied plastic incorporating glass beads under the following conditions will achieve the best results:

- a) air temperature >5°C and ≤35°C
- b) pavement temperature >5°C and ≤45°C
- c) relative humidity <85%
- d) air movement >10 km/h (reasonable air movement), and
- e) adequate protection of lines from traffic during the drying process.

Cold applied plastic must not be applied when relative humidity is above 85% and when air or pavement temperatures are below 5°C.

Cold applied plastic materials must be applied in accordance with the manufacturer's recommended application temperature. Application at the manufacturer's recommended temperature will assist in achieving the correct glass bead embedment depth, to aid bead retention and marking retroreflectivity or night-time visibility. This is an important consideration especially when using the large diameter Type D or Type D-HR glass beads.

Table 7.5.4.2 – Application rates for cold applied plastic and glass beads

Line type	Minimum CAP application rate lit/m ²	Coverage (minimum per coat) g/m ²
Longitudinal lines – Type D-HR beads	0.700	>450
Transverse lines – Type D-HR / antiskid beads	1.000	>500

The application rates cold applied plastic shall not be less than the values specified previously. Application rates may be increased to meet requirements for dry film thickness.

7.6 Raised pavement markers

7.6.1 Application of retroreflective pavement markers

The use of raised retroreflective pavement markers shall be in accordance with Clause 5.6.2 of Part 2 of the MUTCD.

7.6.2 Application of non-reflective pavement markers

The use of non-reflective raised pavement markers shall be in accordance with Clause 5.6.3 of Part 2 of the MUTCD.

7.7 Audio tactile line marking

7.7.1 Application of audio tactile line marking

Audio tactile line marking (ATLM) shall be configured as a pattern of raised ribs. At locations where edge lines have not been marked (such as across narrow structures) ATLM shall not be applied.

ATLM shall be applied in a controlled manner, to produce a finished longitudinal line with a consistent appearance and profile that provides a significant audible warning.

7.7.2 Application on existing painted lines

All extraneous or loose material shall be removed from areas where the material is to be applied, immediately prior to application of ATLM. In addition, existing line markings shall be prepared and primed, in accordance with the manufacturer's recommendations, to ensure satisfactory adhesion of the material.

7.7.3 Placement and dimension of audio tactile line marking

Where nominated in the Contract, ATLM shall be applied to all lines shown on the design documents and shall only be applied to the painted portion of the marked lines. ATLM shall meet the dimensions shown in Figure 7.7.3(a), Figure 7.7.3(b) and Figure 7.7.3(c), and shall conform to the tolerances shown in Table 7.9.2.

Use of ATLMs on Wide Centreline treatments are outlined in Clause 7.11 of this Technical Specification.

The height of the raised ribs is measured from the plane surface formed by the tops of the aggregate.

Diagrams depicting these requirements are provided in Figure 7.7.3(a), Figure 7.7.3(b) and Figure 7.7.3(c).

Figure 7.7.3(a) – ATLM edge line

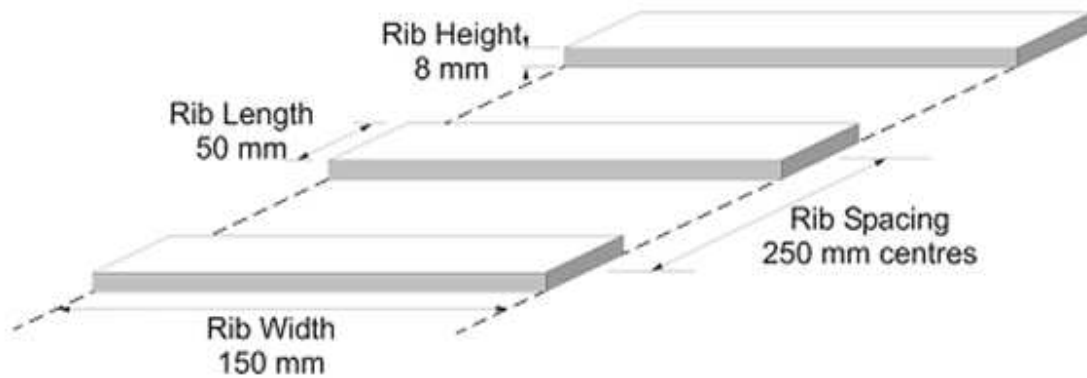

Figure 7.7.3(b) – ATLM centre double barrier lines

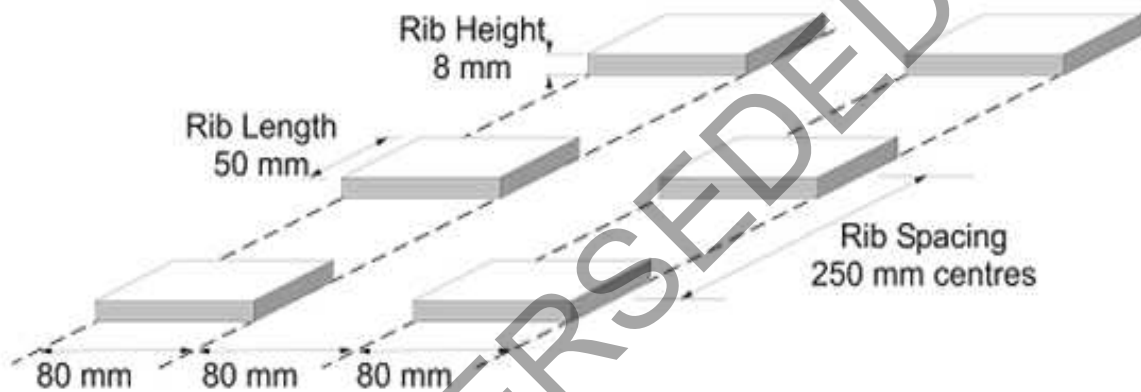
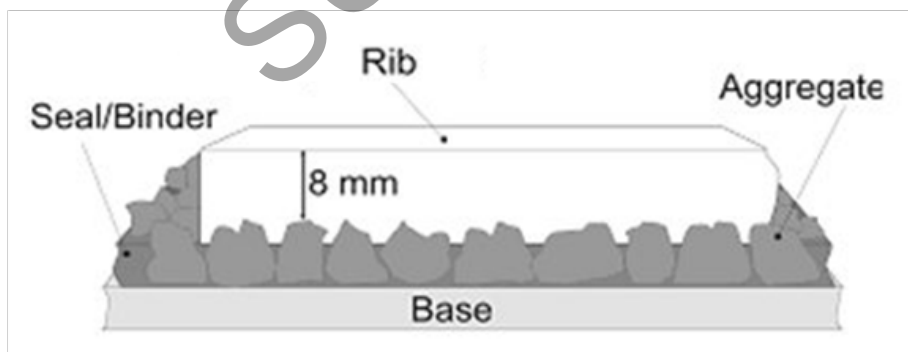

Figure 7.7.3(c) – Height measurement of the raised rib



7.7.4 Gaps for cyclists

A 1.5 m gap spaced every 20 m shall be provided in the ATLM edge line.

7.7.5 Adjacent residences – noise considerations

Refer to TRUM Volume 2 Part 5 for guidelines on the installation of ATLM near residences.

Excerpt from *Traffic and Road use Management (TRUM) manual Volume 2 Guide to Road Safety Part 5 Road safety for rural and remote areas*:

4.4.4 Noise effects

Noise generated by ATLM can be a problem to nearby residents. ATLM should not be installed on either the centre line or the edge line where there is increased potential that vehicles will traverse the ATLM AND where residences are within 200 metres of the application.

7.7.6 Luminance and retroreflectivity

Glass beads in accordance with AS 2009 Type C shall be mixed into the material at a rate of not less than 30% by mass prior to application.

Glass beads in accordance with AS 2009 Type B or B-HR shall be applied immediately to the surface of the material. The minimum rate to be retained on the material's surface is 200 g/m². In order to enhance retention, the beads shall have a proprietary adhesive coating.

The material shall have a minimum titanium dioxide content of 10% by mass.

Acceptance of the retroreflectivity of the road marking shall be based on the marking achieving a minimum level of reflectivity of 350 mcd/lux/m² measured in accordance with Clause 6.1.1.

7.8 Protection of the work

Newly placed pavement markings shall be protected from damage by traffic or other causes, using acceptable traffic management procedures; until the material is dry (no pick-up condition) or has hardened sufficiently to prevent such damage.

7.9 Tolerances

7.9.1 Pavement markings

Completed pavement markings shall:

- a) be uniform
- b) have clean and well-defined edges without running or deformation, and
- c) conform to the dimensions shown on the design documents or in MUTCD.

Longitudinal lines shall be straight on straight alignment and shall be on a true arc on curved alignment.

When completed, pavement markings shall conform to the tolerances specified in Table 7.9.1.

Additionally, arrows and letters shall be placed square to the centreline of the traffic lane.

Drips, overspray, improper markings, and paint and thermoplastic material tracked by traffic shall be immediately removed from the pavement surface by methods which do not damage the pavement surface.

Table 7.9.1 – Tolerances – Pavement marking

Dimension	Tolerance (mm)
Longitudinal lines	
Width of line	±5
Width of gap between adjacent lines	±5
Length of line and / or gap new construction, reseals and asphalt overlays, and repaints	±100 ±300
Placement from spotting for new construction, reseals and asphalt overlays	±20
Placement from existing line (repaints.)	±15
Trueness of line	<15 in 10 m
Transverse markings	
Dimension of transverse markings and shapes	±20
Placement from spotting	±10
Placement from existing markings	±10

7.9.2 Audio tactile line marking

The distance between the centreline of the completed marking and the centreline of the existing painted line marking is to be less than 10 mm.

The apparent line of the markings is to be a smooth, continuous alignment when viewed in the direction of the line.

Audio tactile material shall comply with the requirements of Clause 6.1.5. The contractor shall install ATLM within the limits outlined in Table 7.9.2.

Table 7.9.2 – Audio tactile line marking tolerances

Aspect	Dimension	Tolerance (mm)
Height of raised rib	8 mm	+2, -1
Centre to centre spacing of raised rib	250 mm	±50
Length of raised rib	50 mm	±2
Slope angle of raised rib	45 degrees	Approximately
Width of raised rib (edge line)	150 mm	±2
Width of raised rib (Centre barrier line)	80 mm	±2

7.9.3 Raised pavement markers

When installed, raised pavement markers shall conform to the tolerances specified in Table 7.9.3.

Table 7.9.3 – Tolerances – Raised pavement markers

	Tolerance (mm)	Distance
Lateral position		
barrier / edge line	+25, -50	From edge of line
broken line	±10	From edge of line
flush medians	±10	From edge of line
Longitudinal position		
broken line	±10	1 m from start of line
new construction	±100	1 m from start of line
replacement	±300	1 m from start of line

7.10 Removal of existing pavement markings

Where required under the Contract, existing pavement markings shall be removed by the appropriate method stated in Table 7.10. Where a method is stated in Clause 5 of Annexure MRTS45.1, that method shall be used.

Table 7.10 – Method of removal of existing pavement marking

Method of removal	Duration of result
Abrasive blasting	Permanent
Chip seal	Permanent
Emulsion and sand	<2 weeks
Line grinder (asphalt only)	Permanent
Profiler (asphalt only)	Permanent
Skid resistant enhanced black cold applied resin or plastic	<6 months
Water blasting	Permanent

7.11 Wide centreline treatments

7.11.1 Application of wide centreline treatments

Notwithstanding the requirements of Clause 7.7.3, where wide centre line treatment has been installed, ATLM shall be installed abutting longitudinal line marking. Refer to Section F.8.2 of *Road Planning and Design Manual 2nd Edition* Volume 3 Part 3 Appendix F for detailed guidelines on the application of this treatment.

8 Installation of raised pavement markers and pavement bars

Raised pavements markers and pavement bars shall be installed to the details and in the locations shown on the design documents or in the Queensland *Manual of Uniform Traffic Control Devices*.

Prior to installation of the markers or bars, any material detrimental to the adhesion between the item and the pavement shall be removed.

Adhesive shall be prepared, applied and cured strictly in accordance with the manufacturer's recommendations.

Care shall be taken when heating soft adhesives. A proprietary-built, gas heated kettle shall be employed for this purpose.

9 Compliance testing

9.1 General

Compliance testing of the completed works shall be carried out for each lot during installation and maintenance.

9.2 Testing frequencies and number of tests

The Contractor is responsible for performing sufficient tests to ensure that the Works comply with the Contract, including the requirements of this Technical Specification; however, the Contractor's testing program shall be such that the testing frequencies and number of tests are not less than those stated in Clause 5.3.

9.3 Geometrics

Geometric tolerances shall be checked at regular intervals not greater than those specified in Clause 6 of Annexure MRTS45.1.

10 Supplementary requirements

The requirements of MRTS45 *Road Surface Delineation* are varied by the supplementary requirements given in Clause 7 of Annexure MRTS45.1.

SUPERSEDED

SUPERSEDED