

PLAN - SINGLE GULLY

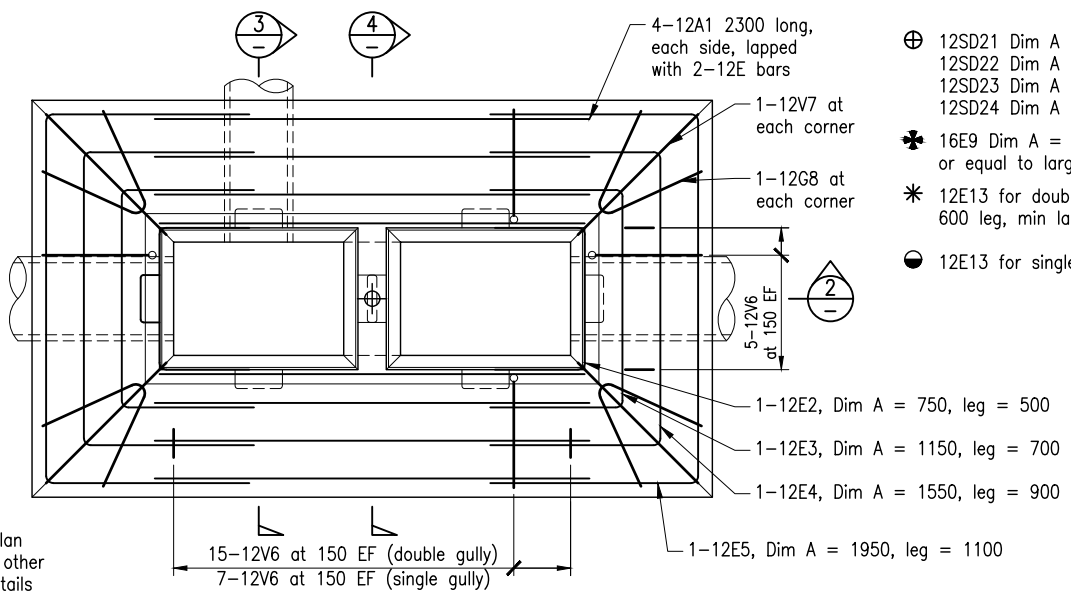

PLAN - DOUBLE GULLY
TYPICAL DETAILS - APRON REINFORCEMENT

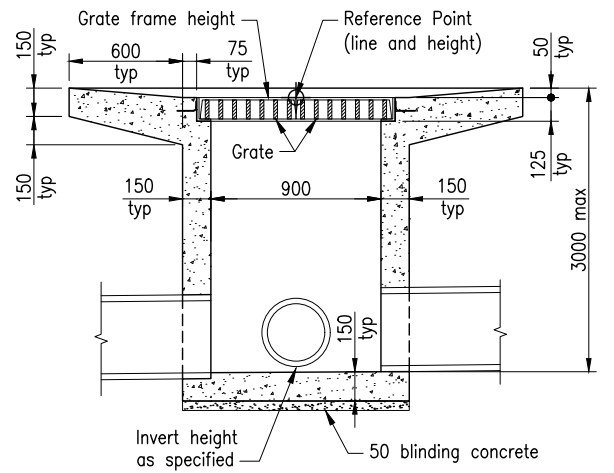

SECTION 1

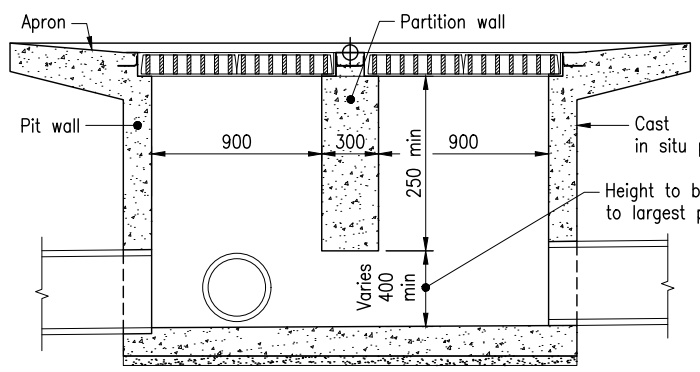

SECTION 2

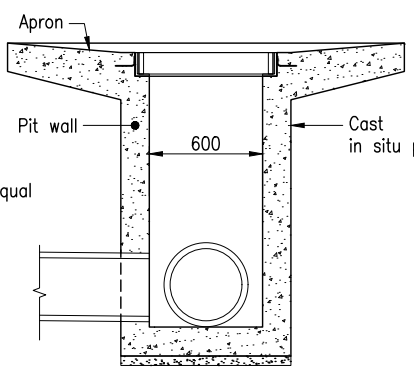

SECTION 3

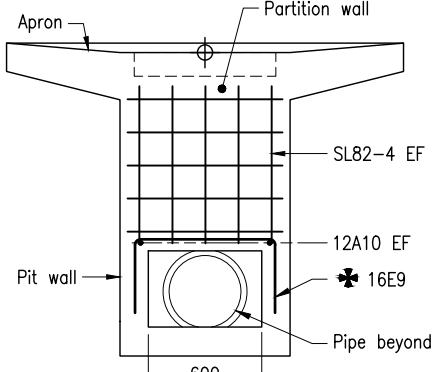

SECTION 4

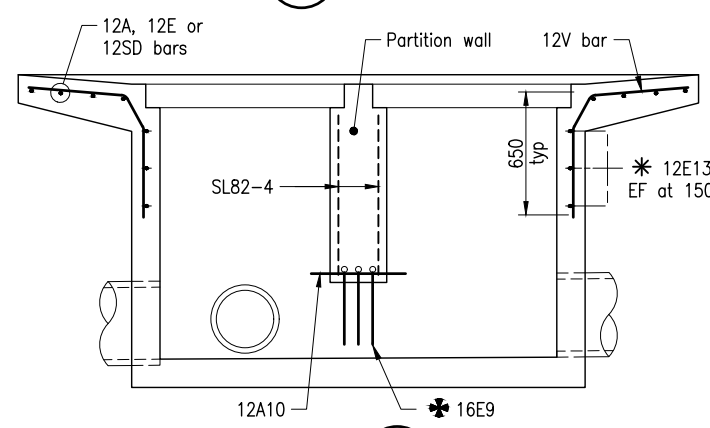

SECTION 2

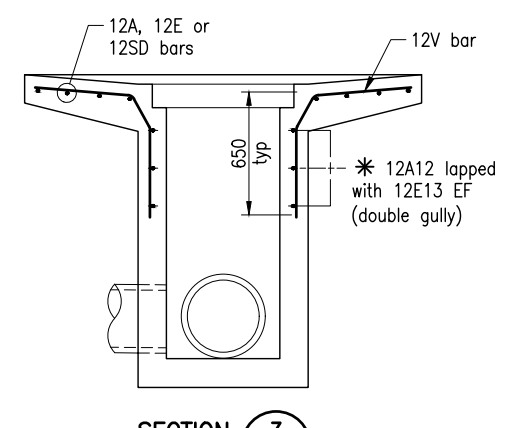

SECTION 3

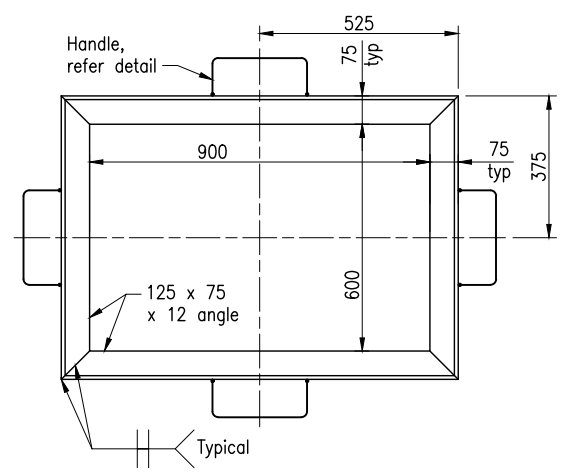

PLAN - GRATE FRAME

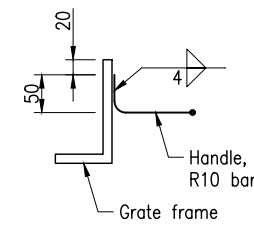

SECTION

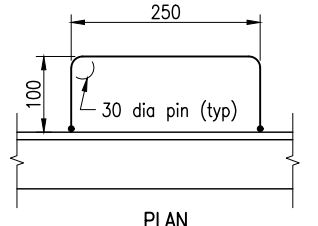

HANDLE DETAIL

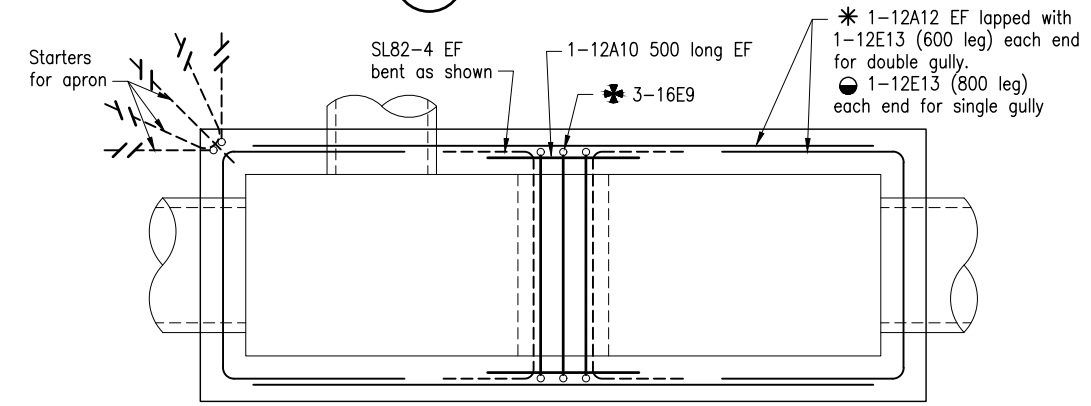

PLAN - TYPICAL REINFORCEMENT FOR DOUBLE GULLY
SINGLE GULLY SIMILAR

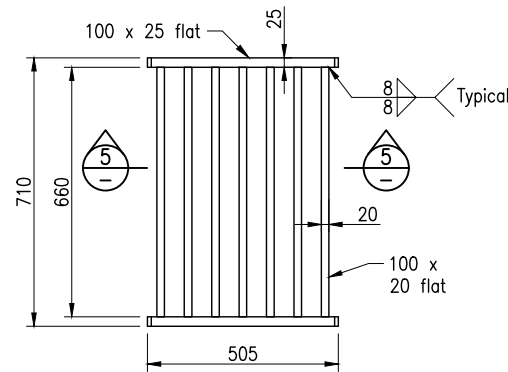

PLAN - GRATE
No OFF = 2 per grate frame

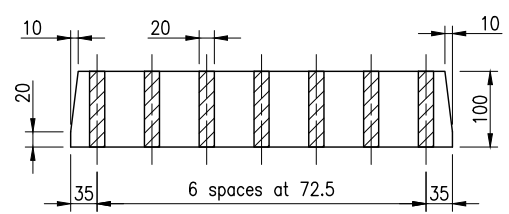

SECTION 5

- ⊕ 12SD21 Dim A = 1050, Dim B = 750
- ⊕ 12SD22 Dim A = 1450, Dim B = 1150
- ⊕ 12SD23 Dim A = 1850, Dim B = 1550
- ⊕ 12SD24 Dim A = 2250, Dim B = 1950
- ✱ 16E9 Dim A = 750 and leg = 400 min or equal to largest pipe dia
- ✱ 12E13 for double gully Dim A = 755, 600 leg, min lap with 12A13 Dim A = 755
- 12E13 for single gully Dim A = 755, 800 leg

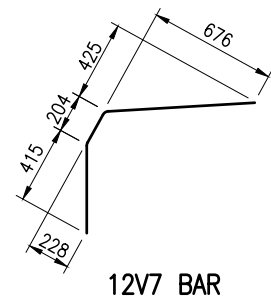

12V7 BAR

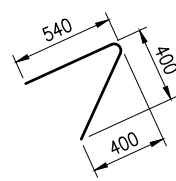

12G8 BAR

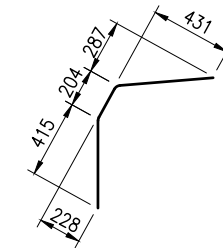

12V6 BAR

NOTES:

1. FIELD INLET CONCRETE GULLY TYPE 1 detailed in this Standard Drawing shall not be used under road traffic.
This standard drawing shall apply to cast in situ field inlet gullies only. Precast pits will require a separate design and drawings, due to additional compaction loads around the pit.
Oversized excavation for the cast in situ construction of this gully pit with subsequent compaction around the pit shall not be used, due to additional compaction loads around the pit.
This field inlet concrete gully has been designed only for construction and maintenance vehicles up to 10t gross weight.
Refer Standard Drawing 1310 for details of Type 2 field inlet concrete gully.
2. Refer to the Road Drainage Manual for guidance in the selection of the appropriate type of field inlet concrete gully for the project.
3. DESIGN LOADS: Load factors and load combinations shall be in accordance with AS 5100. Dynamic load allowance is zero.
LIVE LOAD SURCHARGE: 10 kPa.
LIVE LOAD VEHICULAR: 10t gross weight.
4. CONCRETE shall be in accordance with AS 5100 and MRTS70.
Design life 50 years.
Concrete class S32/20.
Exposure classification B1 to AS 3600.
Cover to reinforcing steel shall be 40.
5. REINFORCING STEEL shall be in accordance with AS/NZS 4671 and MRTS71.
Pits do not require reinforcement other than that shown for the apron and partition wall.
Reinforcing steel shall be read in conjunction with Standard Drawings 1043 and 1044.
Deformed bars Grade D500N. Round bars Grade R250N.
Reinforcing mesh Grade D500L. All reinforcing steel to be ACRS certified.
6. STEELWORK shall be fabricated to the requirements of MRTS78.
Angle shall be Grade 250 (minimum) to AS/NZS 3678.
Flat bar shall be Grade 300 to AS/NZS 3679.1.
All steelwork shall be hot dip galvanized to AS/NZS 4680.
Prior to galvanising all weld splatter and welding slag is to be removed.
7. GRATES AND FRAMES shall comply with the requirements of AS3996 Class C design. For bicycle safe grates, only approved grates and frames shall be used. Bicycle safety testing of grates shall be in accordance with AS 3996. The grate detail shown is a bicycle safe grate. Where bicycles are legally prohibited then approved non-bicycle safe grates may be used.
8. WELDING: Symbols are to AS 1101.3.
Structural Steel welding shall be to AS/NZS 1554.1. All welds, except location tack welds, shall be SP category.
Welding consumables shall be controlled hydrogen type: G493 to AS/NZS ISO 14341-B or T493 to AS/NZS ISO 17632-B.
Reinforcing Steel welding shall be in accordance with Standard Drawings 1043 and 1044.
9. SUBSOIL DRAIN OUTLETS shall be to the requirements of MRTS03. Where the subsoil drain is discharged into a gully pit, the outlet of the subsoil drain should be preferably located above the top of the stormwater pipes.
The subsoil drain outlets shall be provided with pest-proof flaps.
10. PROJECT-SPECIFIC INFORMATION TO BE SHOWN IN THE DOCUMENTS:
Reference Point; frame grate height; connecting pipe details; depth of pit
Steel schedule
11. DIMENSIONS are in millimetres unless shown otherwise.

ASSOCIATED DEPARTMENTAL DOCUMENTS:

- Design Criteria for Bridges and Other Structures
- Road Drainage Manual

REFERENCED DOCUMENTS:

- Departmental Standard Drawings:
 - 1043 Reinforcing Steel - Standard Bar Shapes
 - 1044 Reinforcing Steel - Lap Lengths
 - 1310 Concrete Gully - Field Inlet Type 2
- Departmental Specifications:
 - MRTS03 Drainage, Retaining Structures and Protective Treatments
 - MRTS70 Concrete
 - MRTS71 Reinforcing Steel
 - MRTS78 Fabrication of Structural Steelwork

Department of Transport and Main Roads				© The State of Queensland (Department of Transport and Main Roads) 2023 https://creativecommons.org/licenses/by/4.0/	
CONCRETE GULLY				A3	Standard Drawing No 1309
FIELD INLET TYPE 1		Not to Scale	Date 11/2023		
A	B	C	D	E	