

TYPICAL PLAN
INSTALLED SIDE INLET GULLY

✱ Where any upstream pipe is installed, a 100 dia uPVC slotted pipe stub, 1000 long with end cap, may be installed on the upstream side of the chamber (unless directed otherwise) as a method of dewatering the pipe trench

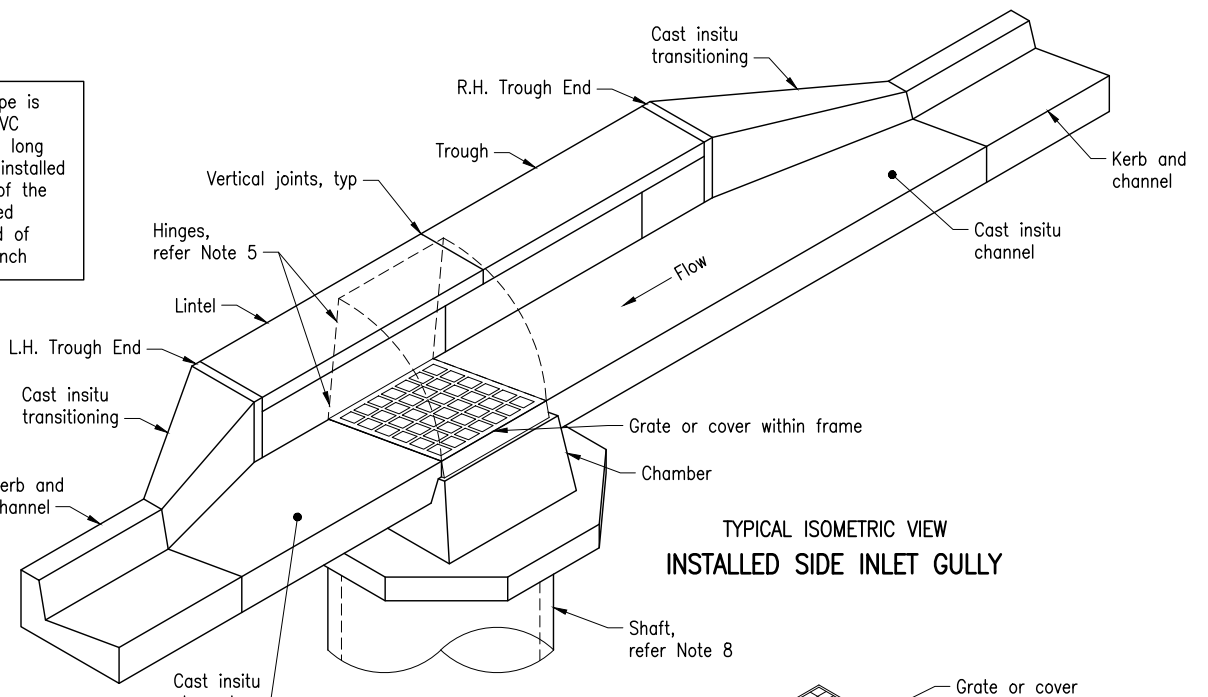

TYPICAL ISOMETRIC VIEW
INSTALLED SIDE INLET GULLY

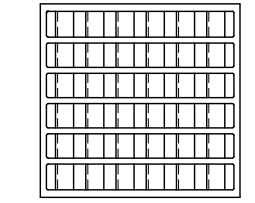
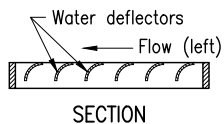

PLAN - GRATE shown in left flow situation.
For right flow, rotate grate through 180°.
TYPICAL VANED GRATE
(Bicycle Safe)

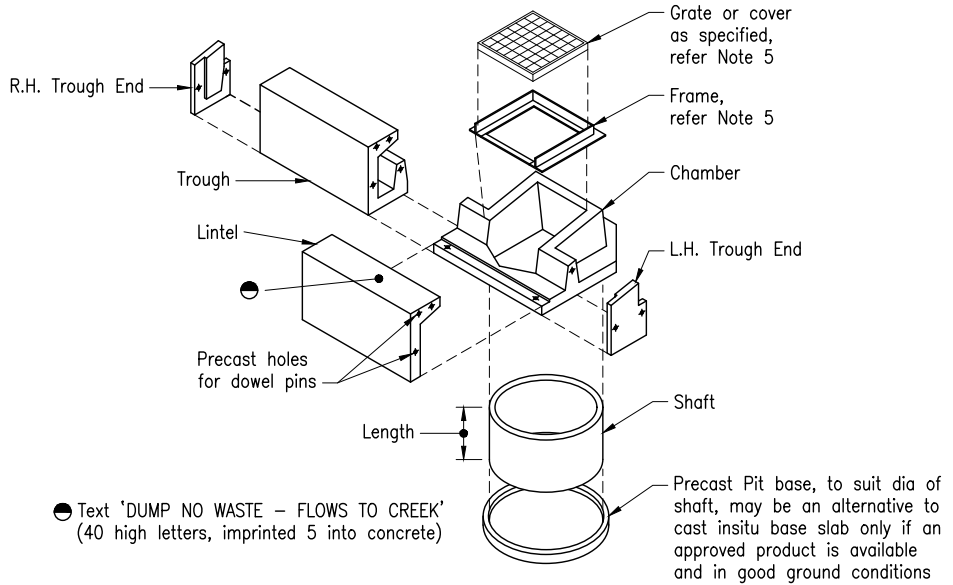

TYPICAL PRECAST COMPONENT ASSEMBLY

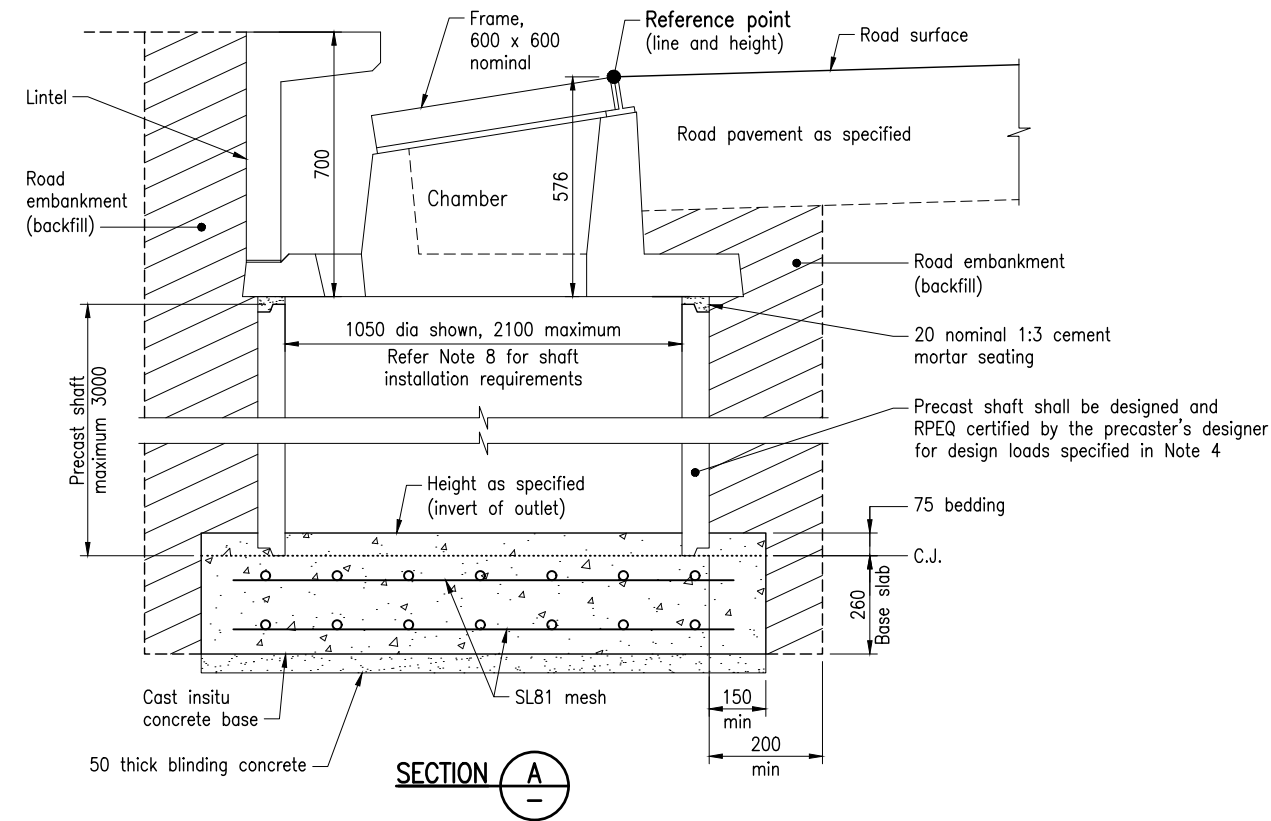

SECTION A

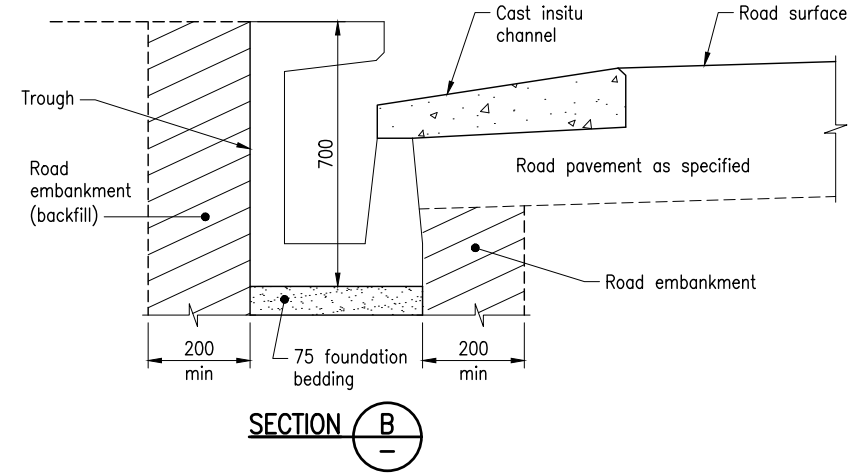

SECTION B

NOTES:

- SCOPE: This Standard Drawing provides details of concrete side inlet gully with precast shaft of maximum depth 3000. Shaft sizes greater than those shown on this drawing shall be a project specific design. Constructability and accessibility of deeper shafts shall be considered in the design. Refer Note 12 for additional design requirements for shafts deeper than 5000. If the gully is on a curved kerb alignment project specific design shall be required. Refer Standard Drawing 1322 for precast concrete side inlet gully with cast insitu pit.
- CONCRETE SIDE INLET GULLIES shall be in accordance with MRTS03.
- DESIGN LIFE: Shafts up to 5000 deep - 50 years for all components.
- DESIGN OF CONCRETE COMPONENTS:
 - Traffic loads and traffic load surcharge shall be in accordance with AS 5100.
 - Load factors and load combinations shall be in accordance with AS 5100.
 - Structural design shall be in accordance with AS 3600
- GRATES, COVERS AND FRAMES shall be Class D to AS 3996. Bicycle safety testing of grates and covers shall be in accordance with AS 3996. Hinged grates and covers are to be provided with a positive mechanical retainer to secure them firmly in place when in the open position. Double hinge system shall to be provided for grates designed to accept flow from one direction. Approved grates, covers and frames shall be used.
- CONCRETE shall be in accordance with MRTS70. Concrete slab base, chamber and shaft S32/20. Concrete channel N32/10. Blinding concrete N20/20. Exposure classification B1 to AS 3600. Minimum cover to reinforcement shall be 40 unless shown otherwise. All exposed edges shall have 19 x 19 chamfers unless shown otherwise.
- REINFORCING STEEL shall be read in conjunction with Standard Drawings 1043 and 1044. Reinforcing steel shall be in accordance with MRTS71 and AS/NZS 4671. Deformed bars Grade D500N and mesh Grade D500L. All reinforcing steel shall be ACRS certified.
- PRECAST COMPONENTS shall be in accordance with MRTS72. Installation, doweled connections and vertical joints shall be in accordance with manufacturer's specifications. Precast components shall be connected by means of dowel pins. These pins shall be manufactured from either T220 minimum grade grey cast iron to AS 1830 or grade 250 steel bar to AS/NZS 3679.1 and hot-dipped galvanized to comply with the requirements of AS/NZS 4680.
- INSTALLATION OF SHAFT - The plane of the top of the shaft shall be installed as follows:
 - Level when measured at right angles to the line of lip of channel
 - To the same grade as the lip of channel when measured parallel to the line of lip of channel.
- CONVERTER SLABS: Approved converter slabs shall be used under the chamber for shaft diameters larger than 1050.
- PROJECT-SPECIFIC INFORMATION TO BE SHOWN IN THE DOCUMENTS: Reference Point; Shaft diameter/height; Converter slab; and Connecting pipe details
- DESIGN REQUIREMENTS for shafts deeper than 5000:
 - Design life 100 years;
 - Minimum exposure classification B2 to AS 5100;
 - Minimum concrete strength S40/20 for shaft; and S32/10 for channel;
 - Cover to reinforcement to AS 5100.
 Concrete components shall be designed for loading as specified in Note 4.
- DIMENSIONS are in millimetres unless shown otherwise.

ASSOCIATED DEPARTMENTAL DOCUMENTS:

- Design Criteria for Bridges and Other Structures
- Road Drainage Manual

REFERENCED DOCUMENTS:

- Departmental Standard Drawings:
- 1033 Kerb and Channel - Kerbs, Channels and Ramped Vehicular Crossing
 - 1043 Reinforcing Steel - Standard Bar Shapes
 - 1044 Reinforcing Steel - Lap Lengths
- Departmental Specifications:
- MRTS03 Drainage, Retaining Structures and Protective Treatments
 - MRTS70 Concrete
 - MRTS71 Reinforcing Steel
 - MRTS72 Manufacture of Precast Elements

Department of Transport and Main Roads			
CONCRETE GULLY			
PRECAST CONCRETE SIDE INLET GULLY WITH PRECAST SHAFT		A3	Standard Drawing No
		Not to Scale	1321
		G	Date 7/2022