

TYPICAL PLAN  
INSTALLED ANTI-PONDING INLET

Text 'DUMP NO WASTE - FLOWS TO CREEK'  
40 high letters, imprinted 5 into concrete

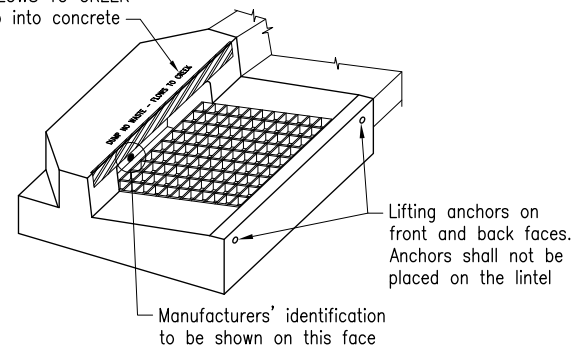

ISOMETRIC VIEW  
PRECAST ANTI-PONDING INLET UNIT

**NOTES:**

- SCOPE: This Standard Drawing provides details of cast insitu roadway type gully with channel lip in line and using the precast anti-ponding inlet unit detailed here. This standard drawing shall be used for the cast in-situ gully pit depth of maximum 3000. Pit sizes greater than the sizes shown on this drawing shall be a project specific design. Constructability and accessibility of deeper pits shall be considered in the design. Refer Note 14 for additional design requirements for pits deeper than 5000.
- PRECAST COMPONENTS shall be in accordance with MRTS72. Precast concrete inlet units shall be approved by the Administrator before use in accordance with MRTS72.
- CONCRETE ROADWAY TYPE GULLIES shall be in accordance with MRTS03.
- DESIGN LIFE: 50 years
- DESIGN LOADS FOR CAST INSITU PITS (all pit sizes and depths):
  - Traffic loads and traffic load surcharge shall be in accordance with AS 5100.
  - Load factors and load combinations shall be in accordance with AS 5100.
  - Structural design shall be in accordance with AS 3600.
- PRECAST INLET UNITS: Reinforcement shall be provided by the designer to obtain the strength required to pass the specified test criteria. For precast lintel units the load detailed in TABLE A shall be applied to each location with separate tests at each location. Acceptance criteria for load testing to be as per AS 1597.1. Precast gully shall be an approved design in accordance with MRTS72. Design shall be proved by load testing. The load detailed in Table A shall be applied with separate tests at each location as marked. Acceptance criteria and method for load testing shall be as per AS1597.1. The lintel unit shall be placed on a compacted confined sand bed (400mm depth max) during test for base. Sand bed is not required for test on lintel. A single casting for the Lintel and Base Unit is preferred. If separate components of lintel and base unit with dowel connection is proposed, the dowel connection shall be designed by precaster's designer and pass the test criteria. Minimum of 4-M16 class 8.8 bolts shall be provided for this connection. Ferrules in the supporting structure shall have 100 minimum embedment and 45 kN minimum anchor design capacity. These minimum anchor requirements are to meet the kerb horizontal design loads in accordance with Clause 11.1 of AS 5100.2.
- CONCRETE shall be in accordance with MRTS70. Minimum grade of concrete and cover to reinforcement shall be as shown in the table below. Exposure classification B1 to AS 3600.

Component	Minimum concrete grade	Minimum cover to reinforcement to AS 3600
Cast in-situ pit	N32/20	40 *
Cast in-situ channel	N32/10	-
Precast inlet unit	N50/20	20 **

- \* - Using standard formwork and compaction  
\*\* - Using rigid formwork and intense vibration. In lieu of intense vibration, approved Super Workable Concrete may be used.
- All exposed edges shall have 19 x 19 chamfers unless shown otherwise.
- REINFORCING STEEL shall be in accordance with Standard Drawing 1044, and MRTS71 and AS/NZS 4671. Mesh Grade D500L. All reinforcing steel shall be ACRS certified.
  - STEELWORK shall be fabricated to the requirements of MRTS78. Steel plate to Grade 250 UNO to AS/NZS 3678. All steelwork shall be hot dip galvanised to AS/NZS 4680.
  - WELDING: Structural Steel welding shall be to AS/NZS 1554.1. All welds, except location tack welds, shall be SP category. Welding consumables shall be controlled hydrogen type: G493 to AS/NZS ISO 14341-B or T493 to AS/NZS ISO 17632-B. Reinforcing Steel welding shall be in accordance with Standard Drawing 1044.
  - LIFTING ANCHORS shall be designed and installed in accordance with MRTS72. Lifting anchors shall be an approved product.
  - GRATES, COVERS AND FRAMES shall be Class D to AS 3996 and comply with MRTS03. Grates and covers shall be tested for BTPR to AS3996. Hinged grates are to be provided with a positive mechanical retainer to secure them firmly in place when in the open position.
  - Provide 10mm mortar (1 cement: 3 fine sand) joint between gully pit and precast inlet units.
  - DESIGN REQUIREMENTS for pits deeper than 5000
    - Design life 100 years for pits; other concrete components 50 years
    - Minimum exposure classification B2 to AS 5100
    - Minimum concrete strength S40/20 for pit; and N32/10 for channel
    - Cover to reinforcement to AS 5100
- Refer Note 5 for concrete design requirements.
15. DIMENSIONS are in millimetres unless shown otherwise.

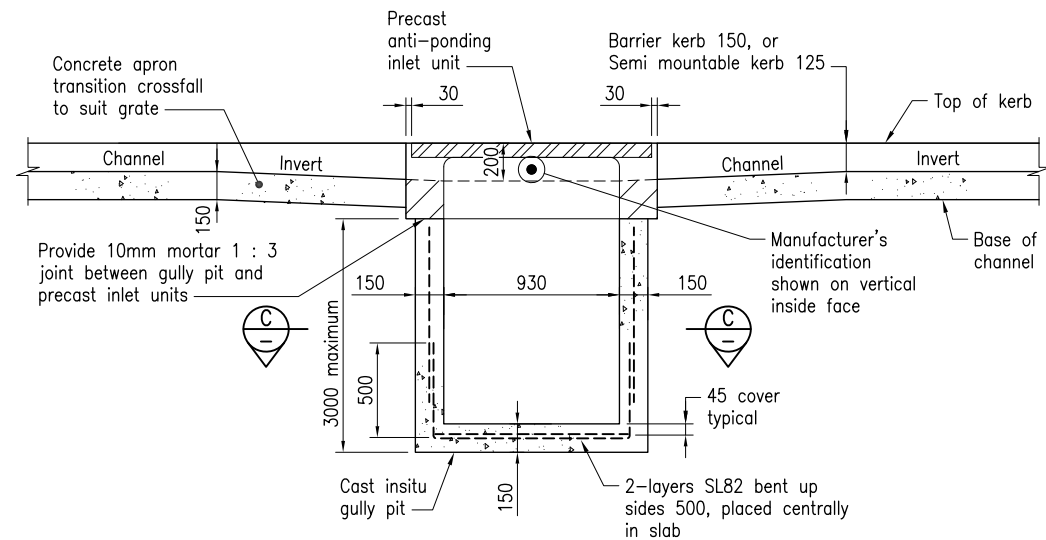

SECTION A ALONG CHANNEL INVERT

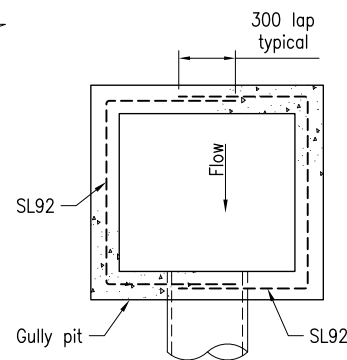

SECTION C

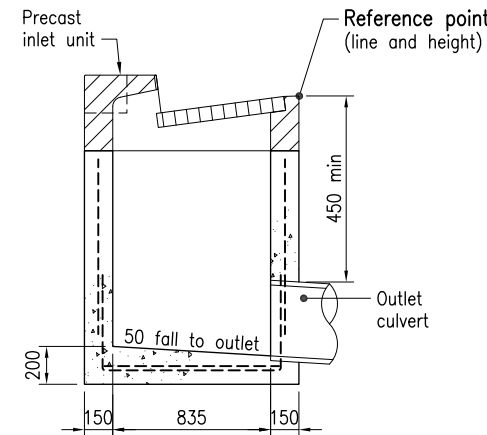

SECTION B

TABLE A - TEST CRITERIA

Refer Note 6

Criteria	Vertical test load
Proof load	50kN
Ultimate load	90kN

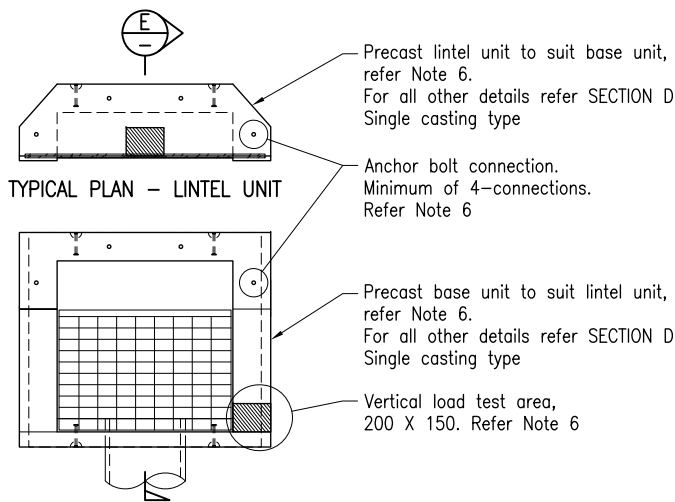

TYPICAL PLAN - BASE UNIT  
ALTERNATIVE DETAIL FOR SEPARATE LINTEL AND BASE UNIT

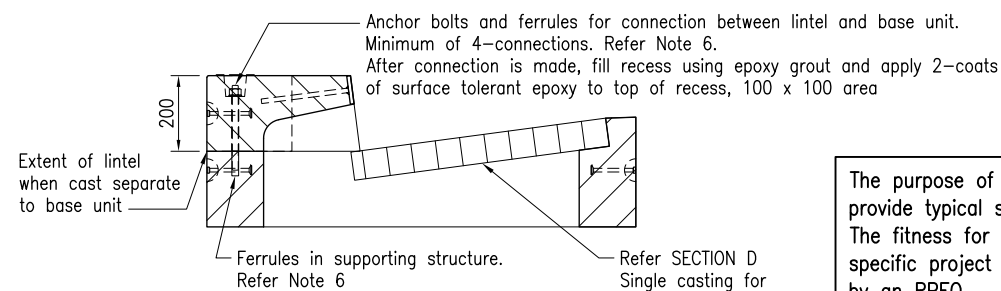

SECTION E ALTERNATIVE DETAIL FOR SEPARATE LINTEL AND BASE UNIT  
Refer Note 6

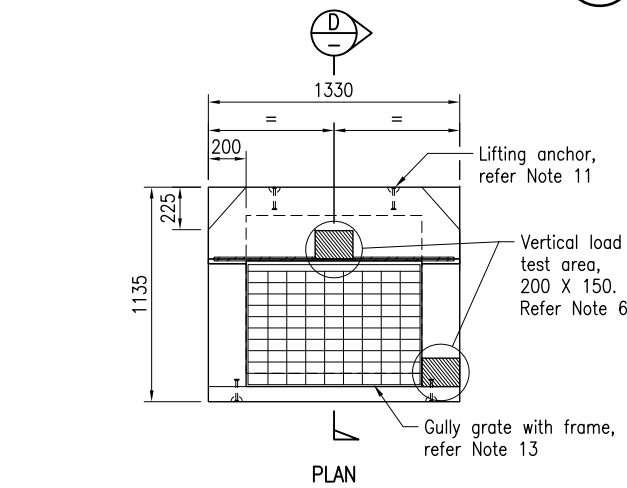

PLAN  
PRECAST ANTI-PONDING INLET UNIT

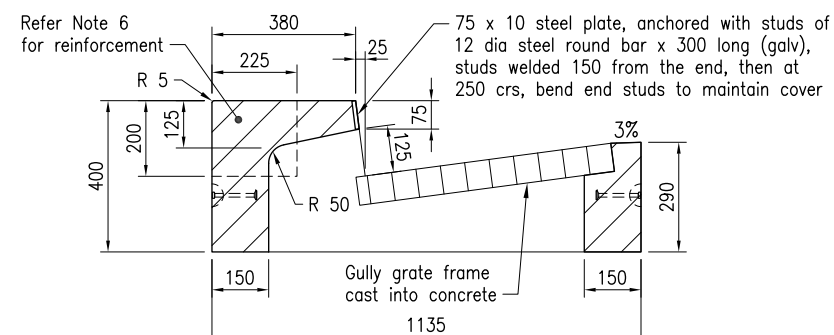

SECTION D SINGLE CASTING

The purpose of This Standard Drawing is to provide typical standard details. The fitness for purpose of these details for a specific project shall be designed and certified by an RPEQ. The details specific to the project location shall be shown on the project specific drawings.

Department of Transport and Main Roads				© The State of Queensland (Department of Transport and Main Roads) 2024 <a href="https://creativecommons.org/licenses/by/4.0/">https://creativecommons.org/licenses/by/4.0/</a>	
CONCRETE GULLY				A3	Standard Drawing No
ROADWAY TYPE CHANNEL LIP IN LINE ANTI-PONDING		Not to Scale	1459		Date 7/2024
A	B	C	D		