

Superseded

**Technical Specification**

**Transport and Main Roads Specifications  
MRTS09 Plant-Mixed Foamed Bitumen Stabilised  
Pavements**

**July 2022**

## Copyright

© The State of Queensland (Department of Transport and Main Roads) 2022.

## Licence



This work is licensed by the State of Queensland (Department of Transport and Main Roads) under a Creative Commons Attribution (CC BY) 4.0 International licence.

## CC BY licence summary statement

In essence, you are free to copy, communicate and adapt this work, as long as you attribute the work to the State of Queensland (Department of Transport and Main Roads). To view a copy of this licence, visit: <https://creativecommons.org/licenses/by/4.0/>

## Translating and interpreting assistance



The Queensland Government is committed to providing accessible services to Queenslanders from all cultural and linguistic backgrounds. If you have difficulty understanding this publication and need a translator, please call the Translating and Interpreting Service (TIS National) on 13 14 50 and ask them to telephone the Queensland Department of Transport and Main Roads on 13 74 68.

## Disclaimer

While every care has been taken in preparing this publication, the State of Queensland accepts no responsibility for decisions or actions taken as a result of any data, information, statement or advice, expressed or implied, contained within. To the best of our knowledge, the content was correct at the time of publishing.

## Feedback

Please send your feedback regarding this document to: [tmr.techdocs@tmr.qld.gov.au](mailto:tmr.techdocs@tmr.qld.gov.au)

## Contents

<b>1</b>	<b>Introduction</b> .....	<b>1</b>
<b>2</b>	<b>Definition of terms</b> .....	<b>1</b>
<b>3</b>	<b>Referenced documents</b> .....	<b>3</b>
<b>4</b>	<b>Standard test methods</b> .....	<b>4</b>
<b>5</b>	<b>Quality system requirements</b> .....	<b>5</b>
5.1	Hold Points, Witness Points and Milestones .....	5
5.2	Construction procedures .....	6
5.2.1	<i>General</i> .....	6
5.2.2	<i>Plant-mixed foamed bitumen stabilised materials</i> .....	6
5.3	Conformance requirements .....	9
5.4	Testing frequencies and lot sizes .....	9
<b>6</b>	<b>Material</b> .....	<b>10</b>
6.1	General .....	10
6.2	Materials to be stabilised (UM1, UM2 or UM3 materials) .....	10
6.2.1	<i>General</i> .....	10
6.2.2	<i>Selection of material type</i> .....	11
6.2.3	<i>Material types</i> .....	11
6.3	Stabilising agents .....	12
6.4	Water .....	14
6.5	Foaming agent .....	14
6.6	Stockpiling of materials .....	15
<b>7</b>	<b>Material compliance testing</b> .....	<b>16</b>
7.1	General .....	16
7.2	Stabilising agents .....	16
7.3	Water .....	16
7.4	UM1, UM2 or UM3 materials .....	17
7.5	Stabilised materials .....	17
7.5.1	<i>General</i> .....	17
7.5.2	<i>Laboratory trial</i> .....	17
7.5.3	<i>Plant production trial</i> .....	18
<b>8</b>	<b>Construction</b> .....	<b>18</b>
8.1	Equipment .....	18
8.1.1	<i>General</i> .....	18
8.1.2	<i>Equipment requirements</i> .....	19
8.2	Program of works .....	21
8.3	Site, services, utilities buildings and drainage .....	21
8.4	Allowable stockpile time .....	21
8.5	Allowable time for placement, compaction and trimming .....	22
8.6	Allowable working time .....	22
8.7	Construction process .....	23
8.7.1	<i>General</i> .....	23

8.7.2	Construction based on process requirements.....	23
8.7.3	Construction based on product standards .....	24
8.8	Construction requirements.....	24
8.8.1	Reclaiming and processing existing pavement materials .....	24
8.8.2	Milling .....	25
8.8.3	Processing of reclaimed granular materials before mixing and stabilising .....	26
8.8.4	Transportation, storage and handling of stabilising agents.....	26
8.8.5	Foamed bitumen properties .....	26
8.8.6	Relative Moisture Ratio of Feed Stockpiles (RMR FSP).....	26
8.8.7	Stockpiling of stabilised materials .....	28
8.8.8	Segregation .....	28
8.8.9	Preparation of surfaces .....	29
8.8.10	Layer thickness.....	35
8.8.11	Placement.....	36
8.8.12	Compaction .....	36
8.8.13	Trimming after compaction.....	37
8.8.14	Period for placement, compaction and trimming.....	37
8.8.15	Construction joints.....	37
8.8.16	Joining new work to existing pavements and structures .....	38
8.8.17	Requirement for trafficking stabilised layer .....	38
8.8.18	Curing .....	39
8.8.19	Maintenance of the stabilised layer.....	39
8.8.20	Bituminous surfacing .....	39
8.8.21	Conditions under which stabilisation and placement shall not proceed.....	39
8.9	Product standards.....	40
8.9.1	General.....	40
8.9.2	Stabilising agent contents .....	40
8.9.3	Relative Moisture Ratio Foamed Bitumen (RMR FB) .....	40
8.9.4	Compaction standard .....	41
8.9.5	Geometrics .....	41
<b>9</b>	<b>Construction compliance testing.....</b>	<b>44</b>
9.1	General .....	44
9.2	Process requirements.....	45
9.3	Product standards.....	45
9.4	Geometrics.....	45
9.4.1	General.....	45
9.4.2	Road roughness (surface evenness) .....	45
9.5	Bituminous stabilising agent content .....	45
9.6	Secondary stabilising agent content.....	47
9.7	Compaction.....	48
9.7.1	Time limits for reference density laboratory compaction.....	49
9.7.2	Time limits for the determination of compacted density.....	49
9.7.3	Time limits for the determination of material biases.....	49
9.8	Relative Moisture Ratio Foamed Bitumen (RMR FB).....	49
9.9	Proof rolling.....	50
9.9.1	Proof rolling prior to early trafficking.....	50
9.9.2	Proof rolling of stabilised layers.....	50
9.10	Acceptance .....	51
<b>10</b>	<b>Supplementary requirements .....</b>	<b>51</b>
	<b>Appendix A: Maximum lot sizes and minimum testing frequencies.....</b>	<b>52</b>

## 1 Introduction

This Technical Specification applies to the construction of stabilised layers in road pavements using a plant-mixed pavement material which comprises a mixture of unbound granular pavement material, foamed bitumen, and a secondary stabilising agent.

This Technical Specification shall be read in conjunction with MRTS01 *Introduction to Technical Specifications*, MRTS50 *Specific Quality System Requirements* and other Technical Specifications as appropriate.

This Technical Specification forms part of the Transport and Main Roads Specifications Manual.

## 2 Definition of terms

The terms used in this Technical Specification shall be as defined in Clause 2 of MRTS01 *Introduction to Technical Specifications*. Further terms are defined as set out in Table 2.

**Table 2 – Definition of terms**

Term	Definition
Allowable time for placement, compaction and trimming	The time within which placement, compaction and trimming of the stabilised material / layer shall be completed. It shall be the difference between the allowable working time and the allowable stockpile time.
Allowable stockpile time	The maximum time that the stabilised material shall be stockpiled, measured from the commencement of incorporation of the stabilising agent added (i.e. mixing of the stabilisation agent added into the material to be stabilised) to when it is first removed from its original stockpile.
Allowable working time	The time within which compaction and trimming of the stabilised layer shall be completed, measured from the commencement of incorporation of stabilising agent added (i.e. mixing of the stabilisation agent into the material) to completion of compaction and trimming of the stabilised material / layer.
Available lime index	The available calcium oxide for quicklime or available calcium hydroxide for hydrated lime in accordance with AS 4489.6.1.
Base course	A layer or layers principally intended to directly support the traffic loads.
Bitumen	Class 170 bitumen that complies with MRTS17 <i>Bitumen and Multigrade Bitumen</i> .
Bound layer	Existing asphalt or previously stabilised pavement layer.
C170 spray seal interlayer	A Class 170 bitumen (C170) spray seal interlayer that is applied to the finished surface of the underlying plant-mixed foamed bitumen stabilised layer. The intent of this seal is to facilitate bonding between multiple plant-mix foamed bitumen stabilised layers.
Curing materials	Materials applied to the exposed surfaces of the completed stabilised layer for the purpose of curing.
Equivalent Standard Axle (ESA)	A single axle with dual wheels loaded to a total mass of 8.2 tonne (80 kN) and with tyres inflated to a pressure of 750 kPa.
Expansion ratio	A term used to define the expansion properties of the bituminous stabilising agent. It is defined as the ratio of the maximum volume of the bitumen in its foamed state to the volume of bitumen once the foaming has completely subsided.

Term	Definition
Feed stockpile	Stockpile of Type UM1, UM2, or UM3 material to be fed in mixing plant for stabilisation.
Finished surface level	Top level of the stabilised layer as specified in the Drawings and Contract documents.
Foamed bitumen	Class 170 bitumen which is temporarily brought into a foamed state by the addition of water and foaming agent(s).
Foaming agent	A chemical additive added to bitumen to improve its foaming characteristics.
Foaming properties	The expansion ratio and half-life of the bituminous stabilising agent.
Hard-cut	The process of cutting back the plant-mixed foamed bitumen stabilised layer surface to uniformly remove a lens of material across the full width of the stabilised layer to produce a roughly textured surface. The rough texture is to facilitate bonding between multiple plant-mix foamed bitumen stabilised layers.
Half-life	A term used to define the expansion properties of the bituminous stabilising agent. It is defined as the time taken for the foamed bitumen to settle to one half of the maximum volume of the bitumen in its foamed state. It is measured from the start of bitumen foaming.
Hydrated Lime	Hydrated Lime is a granular form of lime consisting primarily of calcium hydroxide (Ca(OH) <sub>2</sub> ).
Plant-mixed material	Material mixed in specialised, dedicated equipment that complies with this Technical Specification.
Primary stabilising agent	See 'foamed bitumen'
Relative Moisture Ratio (RMR)	The ratio of the moisture content of a material compared to the optimum moisture content, expressed as a percentage.
Relative Moisture Ratio Feedstock (RMR FSP)	The relative moisture content of the unbound granular materials (UM1, UM2 and UM3) in feed stockpile prior to the incorporation of stabilising agents.
Relative Moisture Ratio Foamed Bitumen (RMR FB)	The relative moisture content of the foamed bitumen treated granular material.
Reclaimed granular materials	Unbound granular material that has been milled or excavated from existing pavement from job site and screened which could be reincorporated into the foamed bitumen stabilisation process.
Secondary stabilising agent	Hydrated lime, or hydrated lime / fly ash blend included in the stabilisation process to improve the dispersion of the foamed bitumen and increase the early strength of the stabilised material.
Secondary weighing system	In lieu of weighbridge, alternative weighing option such as a loader bucket with a calibrated load cell.
Stabilising agents	Foamed bitumen, hydrated lime and / or blended hydrated lime with fly ash.

<b>Term</b>	<b>Definition</b>
Subbase course	A course or courses principally intended to distribute to the subgrade the loads from overlying course(s).
Type UM1 material	An unbound granular material that conforms to the requirements for Type 2.1, 2.2 or 2.3 materials as specified in MRTS05 <i>Unbound Pavements</i> with a minimum CBR (soaked) of 60%. '2.1 and 2.2' particle size distribution as specified in MRTS05 <i>Unbound Pavements</i> .
Type UM2 material	An unbound granular material that, when blended and / or mixed but not stabilised, conforms to the requirements for a Type 2.2 or 2.3 material as specified in MRTS05 <i>Unbound Pavements</i> with a minimum CBR (soaked) of 60%. '2.1 and 2.2' particle size distribution as specified in MRTS05 <i>Unbound Pavements</i> . May include approved reclaimed granular materials.
Type UM3 material	An unbound granular material that, when blended and / or mixed but not stabilised, conforms to the requirements for a Type 2.3 material as specified in MRTS05 <i>Unbound Pavements</i> with a minimum CBR (soaked) of 60%. The particle size distribution of the Type UM3 material shall comply with Table 6.2.3(b) unless otherwise approved or directed by the Administrator. May include approved reclaimed granular materials

### 3 Referenced documents

Table 3 lists documents referenced in this Technical Specification.

**Table 3 – Referenced documents**

<b>Reference</b>	<b>Title</b>
AP-G41/15	<i>Austrroads' Bituminous Materials Safety Guide</i>
AS 2891.13.1	<i>Methods of sampling and testing asphalt – determination of the resilient modulus of asphalt – Indirect tensile method</i>
AS/NZS 3582.1	<i>Supplementary cementitious materials - fly ash</i>
AS 4489.6.1	<i>Test methods for limes and limestones – Lime index – Available lime</i>
MRTS01	<i>Introduction to Technical Specifications</i>
MRTS05	<i>Unbound Pavements</i>
MRTS08	<i>Plant-Mixed Heavily Bound (Cemented) Pavements</i>
MRTS11	<i>Sprayed Bituminous Treatments (Excluding Emulsion)</i>
MRTS17	<i>Bitumen and Multigrade Bitumen</i>
MRTS23	<i>Supply and Delivery of Quicklime and Hydrated Lime for Road Stabilisation</i>
MRTS30	<i>Asphalt Pavements</i>
MRTS50	<i>Specific Quality System Requirements</i>

Reference	Title
MRTS56	<i>Construction Surveying</i>
Pavement Design Supplement	<i>Pavement Design Supplement, Transport and Main Roads</i>
Materials Testing Manual	<i>Materials Testing Manual, Transport and Main Roads</i>

#### 4 Standard test methods

The standard test methods listed in Table 4 shall be used in this Technical Specification, subject to the method of application(s) stated below.

Further details of test numbers and test descriptions are given in Clause 4 of MRTS01 *Introduction to Technical Specifications*.

**Table 4 – Standard test methods**

Property to be Tested	Method No.
Available lime index	AS 4489.6.1
Bitumen content of bitumen stabilised materials	Q118
Calculation of characteristic value of a lot	Q020
California bearing ratio	Q113A
Crushed particles	AS 1141.18
Curing moulded specimens of foamed bitumen stabilised material	Q135C
Degradation factor	Q208B
Deviation from a straightedge	Q712
Fines ratio	Q103A
Flakiness index	Q201
Foreign Material (Type 2 materials containing recycled material)	Q477
Laboratory reference density	Q142A, Q143, Q144A
Lime content of lime treated materials	AS 5101.3.2
Linear shrinkage	Q106
Liquid limit	Q104A
Moisture content	AS 1289.2.1.1, AS 1289.2.1.4, AS 1289.2.1.6
Particle size distribution	Q103A
Petrographic assessment of aggregates	Q188
pH (Type 2 materials containing recycled concrete)	AS 1289.4.3.1
Preparation and compaction of field mix foamed bitumen stabilised material	Q138B
Preparation and compaction of laboratory mixed foamed bitumen stabilised material	Q138A
Proof rolling test	Q723



Property to be Tested	Method No.
Relative compaction	Q140A, Q141A, Q141B
Relative moisture ratio	Q250
Resilient modulus of foamed bitumen stabilised material	Q139
Road roughness (surface evenness)	Q708B, Q708C, Q708D
Sampling – aggregates	Q060 or AS 1141.3.1
Selection of sampling or test sites	AS 1289.1.4.2
Spot sampling of soils, crushed rock and aggregates	Q061
Sulfate content	AS 1289.4.2.1, other published or validated classical chemistry technique or instrumentation technique#
UCS (Type 2 materials containing recycled concrete)	Q115
Water absorption	AS 1141.6.1
Wet strength	AS 1141.22
Wet / dry strength variation	AS 1141.22
Working time of foamed bitumen stabilised materials	Q136B

# Instrumentation techniques may include Ion Chromatography / Inductively Coupled Plasma / Discrete Analyser and so on. NATA endorsed test results are evidence of a validated technique.

## 5 Quality system requirements

### 5.1 Hold Points, Witness Points and Milestones

General requirements for Hold Points, Witness Points and Milestones are specified in Clause 5.2 of MRTS01 *Introduction to Technical Specifications*.

The Hold Points, Witness Points and Milestones applicable to this Technical Specification are summarised in Table 5.1.

**Table 5.1 – Hold Points, Witness Points and Milestones**

Clause	Hold Point	Witness Point	Milestone
5.2.2	1. Approval of construction procedures and construction program.		Supply of the construction procedures and construction program for the stabilisation works (21 days). Submission of samples of materials and all test results to Administrator (21 days)
6.5		1. All stockpiles including feed stockpile prior to incorporation of the stabilising agents	
7.1	2. Compliance of all materials and material sources prior to		

Clause	Hold Point	Witness Point	Milestone
	their incorporation. Acceptance of all test results submitted by the Contractor, including foamed bitumen stabilised materials as per <i>Materials Testing Manual, Part 2 – Application, Section 6 – Testing of Materials for Plant-mixed Foamed Bitumen Stabilisation</i>		
8	3. Construction permitted to proceed		
8.1.2.4	4. Self-propelled spreading machine (paver) trial (if paver is used)		
8.3	5. Survey of services, utilities buildings and drainage		
8.7.2.1	6. Approval of compaction based on a process requirement		
8.7.2.2		2. Construction of trial section (if process standard is specified for compaction)	
8.8.5	7. Foaming properties of bitumen		
8.8.9.1		3. Preparation of surface	
8.8.9.2.1	8. Extent of crack filling		
8.8.9.2.2	9. Extent of stain alleviating geotextile strips		
8.9.2.1			Ordered content of stabilising agents (14 days)
9.8.2		4. Proof rolling test	
9.9	10. Acceptance		

## 5.2 Construction procedures

### 5.2.1 General

The Contractor shall prepare documented procedures for all construction processes in accordance with Clause 6 of MRTS50 *Specific Quality System Requirements*.

The construction procedure described in Clause 5.2.2 shall be submitted to the Administrator.

### 5.2.2 Plant-mixed foamed bitumen stabilised materials

A construction procedure detailing all work described in this Technical Specification shall be prepared.

The construction procedure shall include, but not be limited to:

- a) Details of all plant / equipment associated with the work detailed in this Technical Specification.
- b) General maintenance plan for all plants including mixing equipment.
- c) Start-up procedure of mixing equipment including secondary agents and water supply point.
- d) Plant inspection schedule and recording sheet by operator (daily and / or weekly inspection).
- e) Details of how services, utilities, buildings and drainage components shall be located and / or protected from damage, injury, etc. (refer to Clause 8.3), and
- f) Details of calibration procedures. Calibration of the production plant shall be undertaken at the start of production daily. The calibration procedure for the plant is described below but not limited to:
  - i. Mixing equipment shall be warmed up approximately 10 minutes prior to undertaking calibration.
  - ii. Batch a representative portion of the feed stockpile material (up to 50 tonnes) through the plant. Measure and record the net mass of the feed stockpile material discharged directly from the plant into the secondary weighing system. Follow the plant manufacturer's calibration procedures, entering the net weight of the discharged feed stockpile material into the plant's control system to adjust the calibration factor, and
  - iii. Repeat step ii until the batched net weight of discharged feed stockpile material is within  $\pm 1\%$  of the batch quantity entered into the plant's control system.

Note: For the calibration process, a weighbridge is the preferred weighing option, however where not available or not within close proximity of the production plant, a secondary weighing option may be utilised.
- g) A detailed sequence of operations for all aspects of the stabilisation works, including, but not necessarily limited to:
  - i. Location of the plant mixing and details of manufacturing process.
  - ii. Location of stockpiles, details of stabilising materials (secondary agents and gravels type and sources), foaming agent, water source.
  - iii. Process of recovering reclaimed granular materials.
  - iv. Details of management of stockpiles including reclaimed granular materials.
  - v. Process of blending reclaimed granular materials with virgin quarry materials if required.
  - vi. Details of longitudinal and transverse joints.
  - vii. The length and width of each paving run within a lot.
  - viii. Paving equipment (self-propelled spreading machine or grader). Where the self-propelled spreading machine is selected, details of trial using the proposed machine are submitted to the Administrator as per Clause 8.1.2.4.
  - ix. Single or multiple pavement layers and details of how to prepare the surface as per Clause 8.8.9 (this shall include details for the hard-cut process described in Clause 8.8.9.4 where applicable).

- x. The actions that will be undertaken in unpredicted weather change such as rain falls at the Site of the Works or production after production commences.
  - xi. Details of procedures for working up to, or against, structures, kerb, kerb and channel and road safety barriers, and such as bridges, access chambers, gullies, culverts and concrete medians and any existing pavement cutback point, and
  - xii. Sequence of operations from initial production through to final placement, compaction, trim and maintenance prior to placement of subsequent layer / lot.
  - xiii. Traceability system whereby materials are accurately weighed and tracked from the point of production to placement.
  - xiv. Reconciliation process to accurately determine the actual bitumen stabilising agent content and secondary stabilising agent content of the stabilised materials produced at the plant – consideration shall be given to situations where stabilised materials produced from the plant are not incorporated into the works.
- h) The proposed program of works and production plan of stabilised materials.
  - i) A testing program which shall include, but not be limited to, the testing methodology that shall be used to assess:
    - i. moisture content of feedstock materials and foamed bitumen stabilised materials
    - ii. the compaction standard
    - iii. layer thickness
    - iv. the stabilising agent contents, and
    - v. geometric tolerances.
  - j) Where process requirements are specified in accordance with Clause 8.7, a program for the construction of the stabilisation works.

The following shall also be submitted to the Administrator with the construction procedure:

- a) Details of the proposed source of each stabilising agent; the foaming agent and the water.
- b) Compliance test results of the constituents of the proposed stabilising agents, foaming agents and water to the required specifications.
- c) Compliance test results and a representative sample (if requested by the Administrator) of materials to be stabilised excluding any materials to be reclaimed from the pavement that exists within the extents of works in the Contract.
- d) Compliance test results (resilient modulus) in accordance with Q139 of laboratory mixed foamed bitumen stabilised material to assess the suitability of the material to be stabilised as per the requirements of Clause 7.5.2, and
- e) Compliance test results (resilient modulus) in accordance with Q139 of foamed bitumen stabilised material produced in the Contractor's nominated plant as per the requirements of Clause 7.5.3.

The proposed construction procedure shall be submitted to the Administrator at least 21 days prior to the commencement of stabilisation works. **Milestone**

No stabilisation works shall commence until the details of the sources, compliance test results and samples have been submitted to the Administrator and until, in the opinion of the Administrator, acceptable sources are identified and test results demonstrate compliance with this Technical Specification.

No stabilisation works shall be commenced until the construction procedure for the stabilisation works including all required compliance test results is acceptable to, and approved by, the Administrator.

#### **Hold Point 1**

The cost of all activities associated with the above works and mix design trials including testing shall be deemed to be incorporated into the relevant work items listed in MRS09. No additional payment shall be made to the Contractor for trial mixes.

### **5.3 Conformance requirements**

The conformance requirements that apply to lots of stabilised pavement covered in this Technical Specification are given in Clauses 6 to 9.

### **5.4 Testing frequencies and lot sizes**

For guidance on the testing of unbound granular materials and UM materials, refer to Figures A1(a), A1(b) and A2 of Appendix A.

The maximum lot sizes shall be as stated in Table A1 of Appendix A or otherwise stated in Clause 1.1 of Annexure MRTS09.1.

The minimum testing frequencies shall be as stated in Tables A2(a), A2(b), A2(c), A3 and A4 of Appendix A or otherwise stated in Clause 1.2 and Clause 2 of Annexure MRTS09.1.

Unbound granular materials and UM materials compliance testing requirements shall be as specified in Tables A2(a), A2(b) and A2(c) of Appendix A.

Construction compliance testing requirements shall be as specified in Table A3 of Appendix A.

Geometric and deviation from a straightedge compliance testing requirements shall be as specified in Table A4 of Appendix A.

Notwithstanding the aforementioned requirements, the following shall also apply:

- a) the minimum frequency of testing for the content of each stabilising agent shall not be less than that shown in Table 5.4
- b) the minimum frequency of testing of the half-life and expansion ratio of the bituminous stabilising agent shall not be less than that shown in Table 5.4
- c) the minimum frequency of checking the calibrations of mixing plant and tare of dosing conveyor and secondary agent's weight shall not be less than that shown in Table 5.4
- d) certification of the compliance of each stabilising agent is required for each type and source, and
- e) certification of the compliance of the potable water used is required for each type, source and sulfate content specified in Clause 6.4.

**Table 5.4 – The minimum frequency for calibration and testing for stabilising agent contents and foaming properties**

Test	Minimum Testing Frequency
Calibration of mixing plant	Calibration process shall be undertaken as described in Clause 5.2.2(f) at the start of each shift and prior to the production of foamed bitumen stabilised material. Calibration / taring of the dosing conveyor and secondary agent weigh scales shall be checked and recorded at the start of the production daily. Additional check shall be undertaken if ordered by the Administrator.
Bituminous stabilising agent content	Recorded at least once per 100 tonnes of continuous production with a minimum of one recording in any production run and in any lot. The Contractor shall have a current certificate of calibration for the bitumen tanker and plant. The Contractor shall produce records of actual foamed bitumen content, as and when requested by the Administrator.
Secondary stabilising agent content	Recorded at least once per 100 tonnes of continuous production with a minimum of one recording in any production run and in any lot. The Contractor shall have a current certificate of calibration for the plant.
Foamed bitumen properties (half-life and expansion ratio)	Tested and recorded at the start of each bitumen tanker and every 400 tonnes of production. Test shall be done after the addition of any bitumen to a tanker or ordered by the Administrator. Test is recommended to be done approximately 10 minutes after the start of production to allow adequate system start-up during production.

## 6 Material

### 6.1 General

Regular inspection, sampling and testing of pavement materials (UM1 to UM3) shall be undertaken by the Contractor during production, and construction in accordance with this Technical Specification.

### 6.2 Materials to be stabilised (UM1, UM2 or UM3 materials)

#### 6.2.1 General

Materials to be stabilised shall comply with the following requirements:

- a) they shall be comprised of unbound granular materials as specified in MRTS05 *Unbound Pavements*
- b) they shall conform to this Technical Specification
- c) they shall not include any previously stabilised material, irrespective of the stabilising agent(s) used to stabilise it, unless approved by the Administrator
- d) they shall be free from organic and any other deleterious material
- e) they shall not have a water-soluble sulfate content exceeding 1.9 grams of sulfate (expressed as SO<sub>3</sub>) per litre, and
- f) have a Plasticity Index (PI) that is not exceeding 10% or Linear Shrinkage (LS) that is not exceeding 6%.

The materials used in the Contract shall be the same as the materials supplied as preliminary samples (refer to Clause 5.2.2(c)).

### 6.2.2 Selection of material type

The type of material to be used shall be selected in accordance with the requirements of Table 6.2.2.

The average daily ESA in the design lane in the year of opening shall be as stated in Clause 8 of Annexure MRTS09.1. Where it is not so stated it shall be deemed to be greater than 3,000.

The material type shall be as stated in Clause 8 of Annexure MRTS09.1. Where it is not so stated it shall be UM1.

**Table 6.2.2 – Material types and their permitted applications**

Materials to be Stabilised	Average Daily ESA in Design Lane in Year of Opening*		
	< 1,000	1,000 to ≤ 3,000	> 3,000
Type UM1	Yes	Yes	Yes
Type UM2	Yes	Yes	No
Type UM3	Yes	No	No

\* The average daily ESA in the design lane in the year of opening used in this table are based on a heavy vehicle growth rate not exceeding 10.0% per annum. If the heavy vehicle growth rate exceeds 10.0% per annum in any of the first five years after opening, then the average daily ESA in the design lane for the first five years after opening shall be used instead.

Lower standard UM materials can be considered in certain applications such as lower subbase layers, provided they meet the modulus requirements defined in Clause 7.5.

A higher standard material type than that specified in Clause 8 of Annexure MRTS09.1, may be nominated by the Contractor. For example, if a Type UM3 material is specified in Clause 8 of Annexure MRTS09.1, the Contractor may nominate Type UM2 or UM1 material as an alternative.

### 6.2.3 Material types

The description of UM1, UM2 and UM3 are given below in Table 6.2.3(a).

**Table 6.2.3(a) – Material types**

Material Type	Description
UM1	<ul style="list-style-type: none"> <li>An unbound granular material that conforms to the requirements for Type 2.1, 2.2 or 2.3 materials as specified in MRTS05 <i>Unbound Pavements</i> with a minimum CBR (soaked) of 60%.</li> <li>'2.1 and 2.2' particle size distribution as specified in MRTS05 <i>Unbound Pavements</i>.</li> </ul>
UM2	<ul style="list-style-type: none"> <li>An unbound granular material that, when blended and / or mixed but not stabilised, conforms to the requirements for a Type 2.2 or 2.3 material as specified in MRTS05 <i>Unbound Pavements</i> with a minimum CBR (soaked) of 60%.</li> <li>'2.1 and 2.2' particle size distribution as specified in MRTS05 <i>Unbound Pavements</i>.</li> <li>May include approved reclaimed granular materials.</li> </ul>

Material Type	Description
UM3	<ul style="list-style-type: none"> <li>An unbound granular material that, when blended and / or mixed but not stabilised, conforms to the requirements for a Type 2.3 material as specified in MRTS05 <i>Unbound Pavements</i> with a minimum CBR (soaked) of 60%.</li> <li>The particle size distribution of the Type UM3 material shall comply with Table 6.2.3(b) unless otherwise approved or directed by the Administrator.</li> <li>May include approved reclaimed granular materials.</li> </ul>

**Table 6.2.3(b) – Particle size distribution for type UM3 material**

Test Sieve Size	Percentage Passing the Test Sieve (% By Mass)	
	Upper Limit	Lower Limit
26.5 mm	100	72
19 mm	99	62
13.2 mm	87	52
9.5 mm	77	46
6.7 mm	66	39
4.75 mm	58	32
2.36 mm	45	24
1.18 mm	36	18
600 µm	30	13
300 µm	26	9
150 µm	22	7
75 µm	20	5

### 6.3 Stabilising agents

All stabilising agents shall comply with the relevant Technical Specification or Australian Standard given in Table 6.3 at the time of supply and at the time of incorporation of the material to be stabilised.

**Table 6.3 – Stabilising agents**

Agent	Relevant Technical Specification or Australian Standard
Primary stabilising agent (bitumen)	Class 170 bitumen that complies with MRTS17 <i>Bitumen and Multigrade Bitumen</i> and this Technical Specification. Refer to Clause 8.8.5 for details about the required foaming properties and to Clause 6.5 for details about the foaming agent.  Where handling of bitumen occurs, the procedures to be used shall be consistent with safe handling practices which apply to bitumen-based products as defined in the Austroads <i>Bituminous Materials Safety Guide, AP-G41/15</i> .
Secondary stabilising agent (hydrated lime)	Hydrated lime that complies with MRTS23 <i>Supply and Delivery of Quicklime and Hydrated Lime for Road Stabilisation</i> and this Technical Specification.
Secondary stabilising agent (hydrated lime / fly ash blend)	Hydrated lime blended with Special Grade or Grade 1 fly ash that complies with AS/NZS 3582.1. In all cases, the blend proportion shall be 50/50.



The nominated bituminous stabilising agent content is given in Clause 8 of Annexure MRTS09.1.

If a bituminous stabilising agent content is not stated in Clause 8 of Annexure MRTS09.1, the content shall be 3.5% of the dry mass density of the material to be stabilised.

The nominated bitumen content shall be considered by the *Pavement Designer* with regards to the effect on the *Volume of Binder (Vb)* value used in the *Fatigue Relationship* for CIRCLY design. Refer to Transport and Main Roads *Pavement Design Supplement (PDS)*, Section 6.7 *Foamed bitumen stabilised materials* for more details.

The total time at which the Class 170 bitumen shall be held in the bitumen tanker (or onsite bitumen storage container) at foaming temperature (170°C to 190°C refer to Clause 8.8.5), shall be no greater than 72 hours.

The estimated secondary stabilising agent content is given in Clause 8 of Annexure MRTS09.1. If an estimated secondary stabilising agent content is not stated in Clause 8 of Annexure MRTS09.1, the content shall be 2% of the dry mass density of the material to be stabilised. The secondary stabilising agent content shall not be less than 1.25% of the dry mass density of the material to be stabilised.

At the time of mixing, the secondary stabilising agent shall not be more than three months old, measured from its date of production. The hydrated lime shall have an Available Lime Index of not less than 80%.

Each component of the stabilising agents shall comply with the relevant Technical Specification at the time of its introduction into the plant.

The Contractor shall make allowance for the type of hydrated lime used and the variation of the Available Lime Index of the supplied and used hydrated lime, compared to that used for the laboratory mix design (i.e. adjust the actual application rate of the hydrated lime to ensure the effective dosage achieved is no less than that achieved in the laboratory mix design). The calculation to convert the hydrated lime content used in the laboratory, to the hydrated lime content used at the plant is shown below.

Converted hydrated lime content (%) from laboratory hydrated lime content (%)

$$\text{Rate Q} = (\text{Rate H}) \times \frac{AL_x}{AL_y}$$

where:

Rate Q is the content of hydrated lime to be targeted at the plant (% by mass)

Rate H is the content of hydrated lime nominated in the design (% by mass)

$AL_x$  is available lime index of hydrated lime (%), used in the laboratory mix design testing

$AL_y$  is available lime index of hydrated lime (%), used in construction

For secondary stabilising agent which is a hydrated lime / fly ash blend, the corrected content (%)

$$\text{Rate Q} = (\text{Rate H}) \left[ \left( \frac{P_{FA}}{100} \right) + \left( \frac{P_{HL}}{100} \times \frac{AL_x}{AL_y} \right) \right]$$

where:

Rate Q is the content of secondary stabilising agent to be targeted at the plant (% by mass)

Rate H is the content of secondary stabilising agent nominated in the design (% by mass)

$P_{FA}$  is the proportion of the secondary stabilising agent blend in percent (%) that is fly ash (50%)

$P_{HL}$  is the proportion of the secondary stabilising agent blend in percent (%) that is hydrated lime (50%)

$AL_x$  is available lime index of hydrated lime (%), used in the laboratory mix design testing

$AL_y$  is available lime index of hydrated lime (%), used in construction

#### 6.4 Water

Water used should be potable. Where potable water is not available, the Administrator may consider water from other sources. In all cases, the water used shall contain less than 0.05% sulfates and be free from oil, acids, organic matter and any other matter that could be deleterious to the mixture.

Recycled water shall not be used to foam bitumen. Recycled water shall not be used for any other purpose without the written approval of the Administrator.

The source(s) shall not be changed without the written approval from the Administrator.

#### 6.5 Foaming agent

Foaming agent that is approved by the Administrator shall be added to the bitumen by one of the following methods:

1. Incorporated into the bitumen tanker or storage container at least 30 minutes prior to incorporation of the material to be stabilised, or
2. A metered inline injection system into the bitumen transfer pipe which complies with the following requirements.
  - a. The injection system shall be connected before the foaming water injection point.
  - b. The injection system shall be capable of dosing a foaming agent content between 0.4% and 2% of the bitumen by mass.
  - c. The foaming agent shall be injected in a manner which achieves complete dispersion throughout the bitumen.
  - d. A metering system shall be used to monitor and control the amount of foaming agent that is continuously dosed.
  - e. The foaming agent storage container shall also be graduated or dipped with a graduated dipstick. The volume of foaming agent used for each production lot shall be measured and recorded so that the actual foaming agent content can be calculated.

The foaming agent content shall not be less than 0.4% and not be greater than 2% of the bitumen by mass. It shall be completely and homogeneously blended with (i.e. mixed into) the bitumen before the bitumen is foamed and is incorporated into the material to be stabilised. Foaming agent shall be in a liquid form and mixed in accordance to the Supplier's recommendations.

The following information must be provided by the Contractor to the Administrator with the construction procedures (refer to Clause 5.2.2):

- a) the foaming agent's chemical and physical properties
- b) the recommended method(s) of handling and mixing the foaming agent
- c) the recommended dosage rate of the foaming agent to achieve the required foaming properties
- d) the recommended time for mixing the foaming agent with the bitumen to ensure the end product is uniform
- e) the effective life of the foaming agent in the bitumen at various temperatures
- f) the recommended time within which the foaming agent remains effective, measured from the date of its manufacture (e.g. its 'shelf life'), and
- g) a Safety Data Sheet (SDS) for the foaming agent.

The type and supplier shall not be changed without the written approval from the Administrator.

Calculation for determining the foaming agent content as a percentage of the bitumen by mass.

$$\text{Foaming agent content (\%)} = \frac{V_F \times \rho_F}{M_B} \times 100$$

where:

- $V_F$  = total volume of foaming agent used (L)
- $\rho_F$  = density of the foaming agent (kg/L)
- $M_B$  = total mass of bitumen at 15°C (kg) (refer to Clause 9.5 for calculation details)

## 6.6 Stockpiling of materials

Stockpiles shall be located on clear, even, firm, well-drained ground and in a location where they can be clearly identified.

If a location is stated in Clause 3 of Annexure MRTS09.1, the stockpile(s) shall be so located.

There shall be a separate stockpile or stockpiles for each material of the same standard or type. For the purpose of testing, each individual feed stockpile lot shall be clearly delineated by forming a separate stockpile or stockpiles for each feed stockpile lot.

Stockpile of materials that are blended with reclaimed granular materials, shall be managed by Contractor to comply fully with the requirements of this Technical Specification and inspected by the Administrator.

The stockpiles shall be managed to maintain the moisture as per Clause 8.8.6.

All stockpiles shall be separated from other stockpiles by at least two metres and shall not be more than four metres high.

Processed reclaimed granular materials shall be placed in separate stockpiles prior to use. Where reclaimed granular materials have been stockpiled for some time and is no longer in a free-flowing condition, it shall be reprocessed to ensure that it is free flowing at the time of its use.

No stockpile that, in the opinion of the Administrator, is excessively wet shall be used in the stabilisation works. **Witness Point 1**

## **7 Material compliance testing**

### **7.1 General**

No material shall be incorporated into the works unless it has been demonstrated to the Administrator's satisfaction that all the material to be used in this Contract comply with all the requirements of this Technical Specification and the Contract. **Hold Point 2**

The Contractor is responsible for carrying out sufficient testing to ensure that the material complies with the requirements of this Technical Specification. However, the Contractor's testing program shall be such that the testing frequencies and number of tests are not less than those given in Clause 5.4.

The testing of individual samples shall be carried out in accordance with the test methods described in Clause 4.

The costs associated with material compliance testing shall be deemed to be incorporated in the relevant work items.

The materials / sources used in the Contract shall be the same as those for materials supplied as samples or for which certificates of compliance with this Technical Specification are provided.

Where the feed material is changed during construction from the originally submitted and approved product as described in Clauses 5.2.2 and 7.5, the Contractor shall provide all test results required including that of the foamed bitumen stabilised materials as per *Materials Testing Manual, Part 2 – Application, Section 6 – Testing of Materials for Plant-mixed Foamed Bitumen Stabilisation* with the proposed replacement materials for approval to use.

The associated testing shall be at the expense of the Contractor with no additional costs payable by the Principal.

### **7.2 Stabilising agents**

Sampling and testing shall be carried out in accordance with the relevant Standards and Technical Specifications.

A certificate of test results demonstrating compliance of each of the bituminous and secondary stabilising agents to the relevant Standards and Technical Specifications shall be provided for each load, or part thereof, of each stabilising agent.

### **7.3 Water**

A certificate of test results demonstrating the compliance of each proposed water source shall be provided.

#### 7.4 UM1, UM2 or UM3 materials

Compliance testing of unbound granular materials shall be carried out in accordance with the requirements of Tables A2(a) and A2(b) of Appendix A or otherwise stated in Clause 1.2.1 of Annexure MRTS09.

Compliance testing of UM1, UM2 or UM3 material shall be carried out in accordance with the requirements Tables A2(a), A2(b) and A2(c) of Appendix A or otherwise stated in Clause 2 of Annexure MRTS09.1.

In all cases the material to be stabilised shall also comply with Clause 6.2. Notwithstanding this, the requirements of this Technical Specification take precedence.

Compliance testing of materials shall be undertaken for each lot. A lot shall include only material of the same type. Samples for compliance testing shall be selected by random sampling.

#### 7.5 Stabilised materials

##### 7.5.1 General

Foamed bitumen stabilised material with the secondary stabilising agent(s) shall be tested as per Materials Testing Manual, Part 2 – Application, *Section 6 – Testing of Materials for Plant-mixed Foamed Bitumen Stabilisation* prior to commencing the Works. This shall be undertaken with the proposed materials to demonstrate the capability to attain the specified modulus.

The test results from Clauses 7.5.2 and 7.5.3 shall be included in the Contractor's construction procedure submission (refer to Clause 5.2.2).

All test results submitted as part of the mix design shall be less than 12 months old, unless otherwise approved by the Administrator.

The cost of all activities associated with laboratory and production mix design trials including testing shall be deemed to be incorporated into the relevant work items listed in MRS09. No additional payment shall be made to the Contractor for trial mixes.

##### 7.5.2 Laboratory trial

Laboratory mix design trials shall be undertaken using a representative sample of the proposed UM materials to be used in the works. The laboratory trials shall be undertaken to evaluate the optimum secondary stabilising agent content. The laboratory testing is required to produce a foamed bitumen stabilised mix that meets the modulus design limits as set out in Table 7.5.2.

**Table 7.5.2 – Cured modulus mix design limits for laboratory mixed foamed bitumen stabilised materials**

Average daily ESA in design year of opening	Minimum '3-days cured' modulus (MPa)	Minimum 'soaked after 3-days cured' modulus (MPa)	Minimum retained modulus <sup>1</sup>
< 100	2500	1500	0.4
100 to ≤ 3000	3000	1800	0.45
> 3000	4000	2000	0.5

Note<sup>1</sup>: Retained modulus ratio = 'soaked after cured' modulus divided by the 'cured' modulus.

### 7.5.3 Plant production trial

The nominated mix design selected from Clause 7.5.2 and accepted by the Administrator, shall be used to run a production trial through the Contractor's mixing plant. The UM materials and stabilising agents used in the production trial shall be representative of those to be used in the works. The foamed bitumen stabilised materials produced from the Contractor's mixing plant shall comply with the modulus design limits as set out in Table 7.5.3.

The mixing plant used for the production plant shall be the same plant proposed to be used by the Contractor for production during construction.

Sampling of the stabilised materials shall be undertaken at the plant and the sampling requirements shall be in accordance with Clause 9.7.

**Table 7.5.3 – Cured modulus mix design limits for production plant-mixed foamed bitumen stabilised materials**

Average daily ESA in design year of opening	Minimum 'soaked after 3 days cured' modulus (MPa)	Minimum 'soaked after 7 days cured' modulus (MPa)	Minimum 'soaked after 14 days cured' modulus (MPa)	Minimum retained modulus <sup>1</sup>
All	1000	1400	1800	0.45

Note<sup>1</sup>: Retained modulus ratio = 'soaked after cured' modulus divided by the 'cured' modulus. For plant production, the retained modulus requirement shall only apply to the 14 days cured modulus values.

## 8 Construction

Prior to acceptance (Clause 9.10), manufacturing stabilised materials and construction of a stabilised layer shall not proceed until the Administrator is satisfied that the requirements covered by Clause 8.1 to Clause 8.9.5.5.3 have been adhered to by the Contractor. **Hold Point 3**

### 8.1 Equipment

#### 8.1.1 General

Equipment capable of efficiently carrying out the following functions shall be continuously available to the Site, and be in use as required:

- a) transporting, transferring and storing mix constituents
- b) manufacturing and mixing
- c) delivering the mixture to job Site
- d) paving
- e) compacting and trimming
- f) preparing edges and surfaces
- g) water curing, and
- h) application of the bituminous curing coat, where specified, to the final layer.

### **8.1.2 Equipment requirements**

The equipment specified below shall comply with the minimum specifications listed in the Clause 8.1.2.1 to Clause 8.1.2.7.

Regular calibration of all equipment shall be undertaken in accordance with the manufacturer's guidelines. All calibrations shall be recorded and, where requested by the Administrator, shall be provided to the Administrator as soon as possible, but no later than seven calendar days after the receipt of any such request.

#### **8.1.2.1 Equipment used to transport, transfer and store mix constituents**

The stabilising agents and foaming agent shall be transported and stored using vessels that are both waterproof and watertight. Apparatus used to transfer the stabilising agents and foaming agent between transport and storage vessels shall also be waterproof during the transfer process. These vessels and apparatus shall be emptied and cleaned each time a different material is introduced into them prior to the introduction the different material.

#### **8.1.2.2 Manufacturing and mixing equipment**

The stabilised material shall be mixed using equipment (or plant) that complies with this clause.

Mixing equipment shall meet at least the following requirements:

- a) It shall be a stationary, driven pugmill that is purpose built for the process of mixing road-making materials, and shall be maintained and calibrated so as to be able to produce stabilised material that complies with this Technical Specification.
- b) It shall have storage facilities for water and the foaming agent as required.
- c) It shall have load cells (or an external calibrated secondary weighing system) for the silo containing the secondary stabilising agent.
- d) It shall be capable of producing plant-mixed stabilised pavement material that is uniform and not segregated and complies with this Technical Specification.
- e) It shall be capable of uniformly incorporating all constituent materials into the materials(s) to be stabilised.
- f) It shall have displays that allow continuous monitoring of each mix constituent.
- g) It shall have a minimum rated continuous production rate that is greater of 140 tonnes per hour of complying mix per hour and the Contractor's placing rate. For projects which require limited quantities, production rate less than 100 tonnes per hour of mix complying with this Technical Specification can be allowed subject to the approval from the Administrator.
- h) Equipment shall be operated within the Plant Manufacturer's recommended maximum production capacity.
- i) It shall have a fully computerised and calibrated control system with read-out meters at the plant's control station to allow continuous monitoring of each of the mix constituents. This shall include a variable feed rate with calibrated load-cells for the secondary stabilising agent.
- j) A water pump with flow control to adjust the amount of water. Water distribution system inside the mixing chamber shall be located immediately after foam bitumen incorporation is completed.

- k) It shall have controlled metering systems for the addition of all constituents.
- l) It shall have the necessary conveyors, source of power and controls.
- m) It shall be fitted with a readily accessible inspection or test jet that can be used to confirm the required flow of bitumen and that the required expansion and half-life properties of the foamed bitumen are being achieved.
- n) All bitumen / foaming jets fitted must be self-cleansing, and
- o) where water is to be drawn from an approved source, an efficient filter is to be provided on the suction pipe to ensure that the water is free from anything that could cause blockage of jets, piping, etc. in the equipment.

In addition, the mixing equipment shall be regularly maintained and calibrated, including all meters within the plant, in accordance with the manufacturer's / supplier's recommendations and to ensure the requirements of this Technical Specification are met. The results of equipment calibration checks shall be recorded and reported to the Administrator as specified in Clause 8.1.2.

#### **8.1.2.3 Delivery equipment**

Vehicles used for the delivery of the mix shall be of the open-body truck type, equipped with adequate covers and capable of transporting and discharging the mixture without segregation. If discharging into the hopper of a paving machine, the vehicles shall be designed or equipped with the capacity to efficiently discharge into the hopper consistently and without spillage.

Delivery equipment shall be clean and free from any contaminant. It shall be sufficient to ensure that the mix can be continuously delivered at a rate that is at least equal to the Contractor's placing rate.

#### **8.1.2.4 Paving equipment**

The mixture shall be placed by the equipment nominated in Clause 4 of Annexure MRTS09.1. Where no indication is given in Clause 4 of Annexure MRTS09.1 a grader or a self-propelled spreading machine (paver) shall be used.

Self-propelled spreading machine (paver) shall have the capacity to either:

- a) place and spread the mixture on the prepared surface to the required uncompacted layer thickness, width and shape in one pass, or
- b) spread previously placed windrows of the mixture to the required uncompacted layer thickness, width and shape in one pass.

Self-propelled spreading machine (paver) shall also have the capacity to compact the stabilised layer to between 85% and 95% of the required level of compaction.

A trial section shall be constructed using the self-propelled spreading machine (paver) proposed by the Contractor. **Hold Point 4** A trial section shall be at least 100 m long with longitudinal joints. Trial section shall be offsite unless approved by the Administrator.

Notwithstanding the above, the Administrator may approve other methods of paving (such as a grader placement) in areas where the pavement width is such that the use of a self-propelled spreading machine (paver) is not practical.

If a grader is used to place the stabilised material it shall be manned by a final trim operator.



Where required, the Contractor shall ensure a grader is available onsite to complete the hard-cut (refer to Clause 8.8.9.4.2).

Irrespective of what equipment is used, the stabilised material shall be placed and spread such that there is no segregation of the mixture.

#### **8.1.2.5 Equipment for preparation for the layer edges and surfaces**

The equipment for the preparation of the layer edges shall be capable of cleanly and neatly cutting the edges vertically and removing all the cut material from the formation.

The equipment for the preparation of the surface of each layer shall include equipment capable of sweeping the layer. It shall also be capable of evenly distributing the tack coat at the required rate on the layer's surface and edges (where required).

#### **8.1.2.6 Equipment for water curing**

The equipment used for water curing shall have the capacity to store at least 6,000 litres of water and be capable of discharging the water in a fine and even mist over the pavement surface in a manner that avoids slurring of the surface, pavement instability and erosion, and leaching of the stabilising agent.

#### **8.1.2.7 Other equipment**

Equipment used to produce the foamed bitumen stabilised material shall include aggregate screens for reclaimed granular materials that shall be used to control the particle size distribution of the material introduced into the mixing equipment.

Front end loader bucket shall be clean and free of debris at all times.

### **8.2 Program of works**

The Contractor shall submit the proposed program of the stabilisation works to the Administrator at least 21 days prior to the commencement of Works, unless otherwise agreed with the Administrator.

Works shall not commence until the program has been approved by the Administrator (refer to Clause 5.2.2 and Hold Point 1).

### **8.3 Site, services, utilities buildings and drainage**

A survey of the Site to determine the location and depth of services, utilities, buildings and drainage components shall be carried out prior to commencement of construction. The survey shall include details of how these, equipment and personnel on Site shall be protected and how the construction Works shall be completed without any detrimental effects to them. The survey shall be included in the proposed construction procedure (refer to Clause 5.2.2).

Works shall not commence until the survey has been completed and a copy of the report provided to the Administrator. **Hold Point 5**

### **8.4 Allowable stockpile time**

The time that the stabilised material can be stockpiled is measured from the commencement of incorporation (i.e. mixing) of the foamed bitumen into the material to be stabilised, to when it is first removed from its original stockpile to the job site.

The maximum allowable stockpile time shall be as stated in Clause 9 of Annexure MRTS09.1. Where it is not so stated, it shall be five hours.

In instances where stabilised materials cannot be removed from the stockpile within the allowable stockpile time due to unforeseeable circumstances, the Administrator may consider extending the allowable stockpile time. In this circumstance, the Contractor shall be responsible to complete works including delivery, placement, compaction and trimming within the allowable working time specified in Clause 8.6.

#### **8.5 Allowable time for placement, compaction and trimming**

The time after discharge from the truck within which placement, compaction and trimming of the stabilised layer shall be completed is the difference between the allowable working time (refer to Clause 8.6) and the allowable stockpile time (refer to Clause 8.4).

The maximum allowable time for placement, compaction and trimming shall be as stated in Clause 10 of Annexure MRTS09.1. Where it is not so stated, it shall be three hours.

Notwithstanding the above, it shall not exceed three hours.

#### **8.6 Allowable working time**

The allowable working time is measured from the commencement of incorporation (i.e. mixing) of the foamed bitumen into the material to be stabilised, to the completion of compaction and trimming of the stabilised materials (excluding static multi-tyre rolling).

The maximum allowable working time shall be as stated in Clause 11 of Annexure MRTS09.1. Where it is not so stated, it shall be eight hours.

Rework to meet this Technical Specification shall be performed in full depth of individual layer within 24 hours.

Alternatively, prior to placement of any stabilised materials, the Contractor may elect to undertake working time testing to determine if the allowable working time for the Contractor's approved stabilised materials can be extended beyond specified the 8 hour limit.

The Contractor shall use Test Method Q136B and report all test results to the Administrator for consideration.

The working time limit will be defined as the lesser of the following values:

- the delay time that produces a 20% reduction in achieved reference three-day soaked modulus (that is, 100% to 80%), or
- the delay time that achieves the three-day soaked modulus value that is equal to the modulus adopted in the pavement design (typically  $\geq 1,800$  MPa).

After consideration of the Test Method Q136B test results, the Administrator may allow a longer working time beyond the specified 8 hour limit. However, in all cases:

- Any extension to the allowable working time shall be added to the allowable stockpile time only.
- The allowable time for placement, compaction and trimming shall not exceed three hours.
- The allowable working time shall not exceed 16 hours.

## **8.7 Construction process**

### **8.7.1 General**

The construction process shall be based either on a process requirement that complies with Clause 8.7.2 or a product standard that complies with Clause 8.7.3. The method for the Contract shall be as stated in Clause 8 of Annexure MRTS09.1. Where it is not so stated in the Annexure, product shall apply.

### **8.7.2 Construction based on process requirements**

Construction based on a process requirement shall:

- a) incorporate the methodology and construction of trial sections in accordance with the requirements of Clauses 8.7.2.1 and 8.7.2.2
- b) comply with the construction requirements stated in Clause 8.8, and
- c) comply with the product standards stated in Clause 8.9 except that, for sections represented by a trial section in which the required compaction is achieved, compaction testing shall not be required on completed works other than trial sections.

#### **8.7.2.1 Methodology**

Each section of the works with a specific combination of stabilising agent type(s), stabilising agent content(s), material(s) to be stabilised, pavement thickness and pavement/subgrade support shall be identified as a separate area for construction.

A trial section shall be constructed for each separate area for construction in accordance with the requirements of Clause 8.7.2.2.

The compaction of each trial section shall be tested in accordance with Clause 5.4 and checked for compliance with Clause 8.9.4. If the minimum characteristic value of the relative compaction results for the trial section is not less than the value specified in Clause 8.9.4, no further compaction testing shall be carried out for the balance of the area for construction that is represented by that trial section, provided that the same construction plant, processes and methodology are used to construct the remaining area as that used for the construction of the trial section.

If the minimum characteristic value of the relative compaction results for the trial section is less than the value specified in Clause 8.9.4, the trial section shall be rectified so that it complies with this Technical Specification and an additional trial section shall be constructed and assessed in accordance with this Clause 8.7.

Construction based on a process requirement and a trial shall not be used for the balance of any works without approval of the Administrator. **Hold Point 6**

#### **8.7.2.2 Trial section**

A trial section shall be constructed using the same construction plant, processes and methodology that it is proposed to use for the remainder of the works represented by the trial section.

#### **Witness Point 2**

A trial section shall be at least 100 m long and include longitudinal joints described in Clause 8.8.15.2.

All operations, testing, etc. required by this Technical Specification, including compaction testing, shall be used in the construction and testing of each trial section.

#### **8.7.3 Construction based on product standards**

Construction based on a product standard shall:

- a) comply with the construction requirements stated in Clause 8.8, and
- b) comply with the product standards stated in Clause 8.9.

### **8.8 Construction requirements**

#### **8.8.1 Reclaiming and processing existing pavement materials**

The parts of existing pavement(s) to be reclaimed via milling or approved alternative method shall be those described in Clause 12 of Annexure MRTS09.1. Where no details are given in Clause 12, of Annexure MRTS09.1, no materials shall be reclaimed.

The Contractor shall process all materials to be reclaimed (e.g. refer to Clause 8.8.3) with the aim of reusing them to produce a material that is suitable for stabilisation (refer to Clause 6.2). This may include blending the reclaimed granular pavement materials with other materials (e.g. imported materials). The proportion and amount of reclaimed granular materials reused shall be maximised and approved by Administrator.

## **8.8.2 Milling**

### **8.8.2.1 General**

The parts of existing pavement(s) to be:

- a) Milled with the Contractor being responsible for removal and disposal of all milled materials shall be those described in Clause 13 of Annexure MRTS09.1.
- b) Milled with the Principal taking possession of all milled materials shall be those described in Clauses 14.1 and 14.2 of Annexure MRTS09.1.

Where no details are given in Clauses 13 or 14 of Annexure MRTS09.1 no milling shall occur.

In addition:

- a) where the Contractor takes possession of milled materials the work shall comply with Clauses 8.8.2.1 and 8.8.2.2, and
- b) where the Principal takes possession of milled materials the work shall comply with Clauses 8.8.2.1 and 8.8.2.3.

Milling shall be undertaken to comply with the requirements of Clause 8.9.5.2.1. Any material removed in excess of the tolerances given in Clause 8.9.5.2.1 shall be replaced as follows:

- a) Where the exposed material at the bottom of the area milled is all unbound granular material, then foamed bitumen stabilised material that complies with this Technical Specification shall be used to replace the material milled off below the specified depth plus 10 mm.
- b) In all other cases the material milled off below the specified depth plus 10 mm shall be replaced with a like material that is approved by the Administrator.

Milling shall be undertaken such that damage to the remaining pavement, relieving slabs, bridge abutments, kerb, kerb and channel or other structures is avoided. Further, milling in these circumstances shall be undertaken in a manner that is approved by the Administrator. The Contractor shall restore at no cost to the Principal any area or items damaged during the milling operations.

### **8.8.2.2 Removal and disposal of milled materials**

Where specified in Clause 13 of Annexure MRTS09.1, the Contractor shall mill the existing pavement to the dimensions specified in the drawings or Contract. The Contractor shall be responsible for the removal and disposal of all such milled materials. Further, this removal and disposal shall comply with Clause 10 of MRTS01 *Introduction to Technical Specifications*.

### **8.8.2.3 Milled materials to be returned to the Principal**

Where specified in Clause 14.1 of Annexure MRTS09.1, the Contractor shall mill the existing pavement to the dimensions specified in the drawings or Contract.

The Contractor shall then remove the milled materials, load them into transport vehicles, transport the materials to the stockpile site(s) specified in Clause 14.2 of Annexure MRTS09.1 or approved by Administrator and unload / stockpile the materials at the nominated site(s). Stockpiling shall comply with the requirements of Clause 6.6.

### 8.8.3 Processing of reclaimed granular materials before mixing and stabilising

Screens shall be used to control the particle size distribution of the reclaim material introduced into the mixing equipment. The materials to be stabilised shall be passed through screens to disaggregate it into different sizes. Oversize particles shall not be used in the stabilised material.

Screened reclaimed granular materials shall be controlled to ensure uniformity and homogeneity of materials to be achieved when they are blended with imported MRTS05 *Unbound Pavements* compliant materials.

The Contractor shall be responsible for the removal and disposal of all unsuitable materials, and the cost of this shall be deemed to be included in the rate of the relevant schedule item or Contract price (i.e. no additional payment shall be made by the Principal). Materials containing the disaggregated materials shall be complied as specified in Clause 6.2 prior to incorporating with the stabilising agents.

### 8.8.4 Transportation, storage and handling of stabilising agents

Bitumen and bitumen mixed with foaming agent shall be transported, stored, handled and transferred using the recommended equipment and procedures described in Austroads *Bituminous Materials Safety Guide* (AP-G41/15). Notwithstanding this requirement, bitumen and bitumen mixed with foaming agent shall be transported, stored, handled and transferred as specified in MRTS17 *Bitumen and Multigrade Bitumen*.

The hydrated lime shall be transported and stored using equipment that is both waterproof and watertight. Equipment used to transfer the secondary stabilising agent shall also be waterproof during the transfer process.

### 8.8.5 Foamed bitumen properties

The foamed bitumen shall exhibit an expansion ratio that is greater than 10 and a half-life that is greater than 20 seconds. This shall be achieved following the incorporation of the foaming agent and then tested in accordance with Clause 5.4. The bitumen incorporation into the material to be stabilised from the bitumen storage container shall commence at a temperature between 180°C and 190°C. Bitumen temperature shall not fall below 170°C throughout the bitumen incorporation process. The foaming properties of the bituminous stabilising agent within the mixing equipment shall be determined using the external test / inspection jet / nozzle. The bituminous stabilising agent shall not be incorporated into the material to be stabilised where the foaming properties of it do not comply with the requirements of this Technical Specification. **Hold Point 7**

### 8.8.6 Relative Moisture Ratio of Feed Stockpiles (RMR FSP)

The moisture ratio of feed stockpile shall be determined prior to incorporation of the stabilising agent in accordance with Test Method Q250 and reported to the Administrator.

The sampling locations shall be determined using Test Method AS 1289.1.4.2. Sampling shall be undertaken in accordance with Test Method AS 1141.3.1. The minimum testing frequency shall be as per Clause 5.4.

The Contractor shall ensure that the relative moisture ratio of the feed stockpile (RMR FSP) complies with the requirements specified in Table 8.8.6.

**Table 8.8.6 – Feed stockpile relative moisture ratio requirements**

Property	Minimum value (%)	Maximum value (%)
Relative moisture ratio of the feed stockpile (RMR FSP)	20	55

The required relative moisture ratio for the blended material feed stockpile (RMR FSP) and the foamed bitumen stabilised material (RMR FB) is shown in Figure 8.8.6. The materials and stockpile management shall meet the requirement in accordance with Clauses 6.2, 6.6 and 8.8.7.

**Figure 8.8.6 – Required moisture content for feed stockpile and stabilised materials**

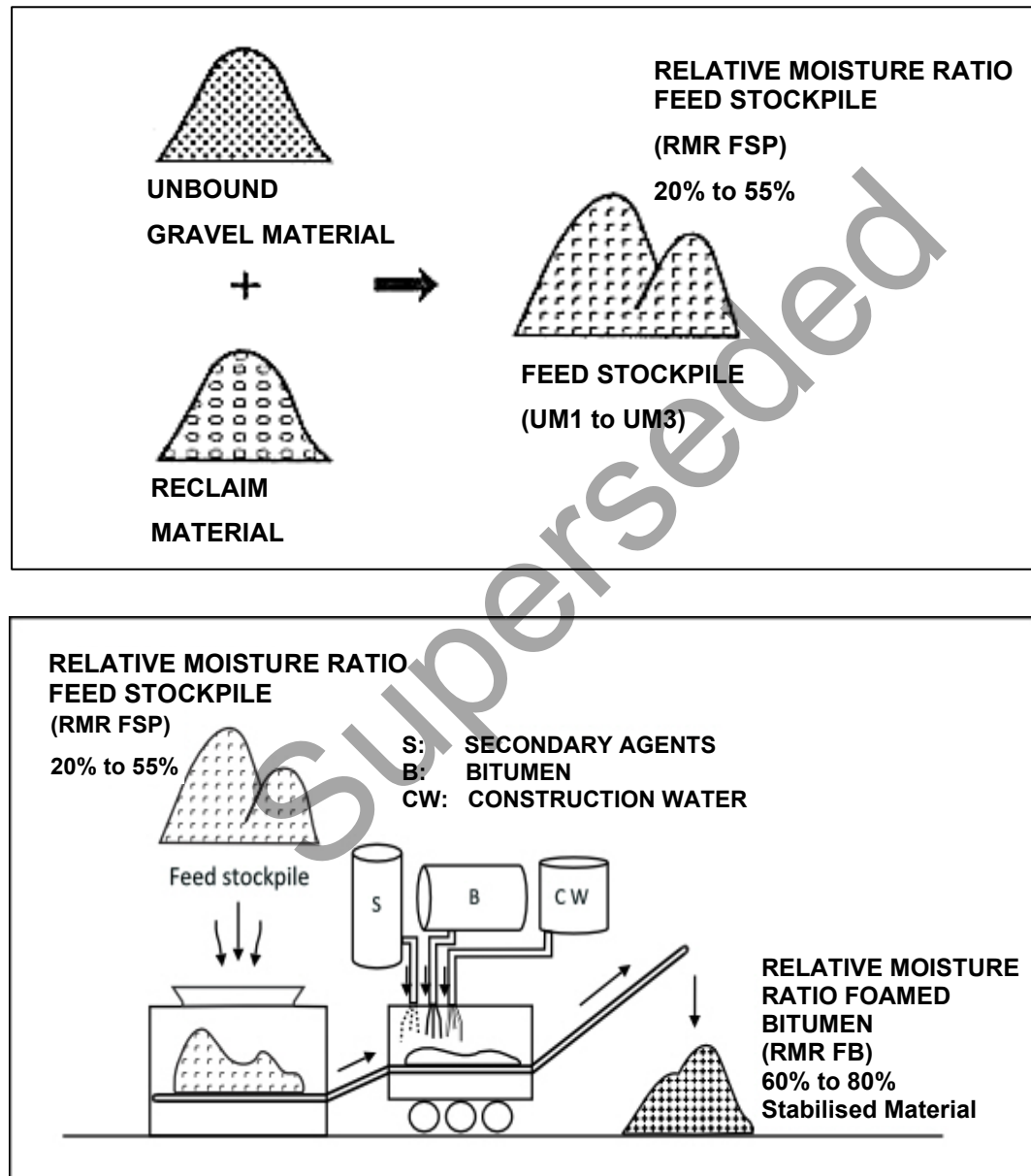

The RMR FSP values have been written around the Department's experience with *Wirtgen KMA 220* mobile cold recycling mixing plant. In the case where the Contractor elects to use an alternative high-production plant, the Administrator is encouraged to contact Director Pavement Rehabilitation (3066 7728) to discuss acceptable RMR FSP values based on complying stabilised material produced in the Contractor's nominated plant.

The Contractor should investigate what specific range of RMR FSP (within the specified 20 to 55%) and RMR FB (within the specified 60 to 80%) would be most suitable for the production, transport and placement of the plant-mixed foamed bitumen stabilised materials.

### **8.8.7 Stockpiling of stabilised materials**

Stockpiles shall be located on clear, even, firm, well-drained ground and in a location where they can be clearly identified.

Stockpile pad shall be prepared so that there is no contamination of stabilised material during the handling and loading processes.

Stabilised material may be stockpiled such that material can be continuously, consistently delivered at a rate that is at least equal to the Contractor's placing rate provided that all allowable times given in Clauses 8.4, 8.5 and 8.6 are not exceeded. Any stabilised material in stockpiles older than eight hours, measured from the incorporation of the foamed bitumen into the material to be stabilised, or where allowable times given in Clauses 8.4, 8.5 and 8.6 for stockpiled materials are exceeded shall not be used unless approved by the Administrator.

Stabilised materials shall be protected with cover or light plastic material to prevent the ingress of moisture and other contaminant.

Stockpiles of stabilised material shall comply with the requirements of Clause 6.6.

### **8.8.8 Segregation**

Segregation is the uneven distribution of particle sizes. The entire construction process, including mixing, stockpiling, transporting and paving, shall minimise segregation so that the particle size distribution of the material in the pavement complies with the particle size distribution requirements specified, with due allowance being made for the inclusion of the stabilising agents.

Further, the material laid ready for compaction shall not have any visible areas of segregation. Any segregated areas should be removed and disposed of in accordance with Clause 10 of MRTS01 *Introduction to Technical Specifications* and replaced with fresh mix before compaction commences. No separate or additional payment shall be made for the removal and disposal of segregated material or the supply of the fresh mix. The cost of all activities associated with the removal and disposal of segregated material and material to replace the segregated material shall be deemed to be incorporated into the relevant Works.

The Administrator may arrange for testing of the particle size distributions or stabilised layer to evaluate areas of suspected segregation.



## 8.8.9 Preparation of surfaces

### 8.8.9.1 General

Where a stabilised layer is to be placed on the surface of a bound pavement layer or on concrete, the Contractor shall carry out the works detailed in this clause and Clause 8.8.9.2. **Witness Point 3**

Bound pavements include asphalt and cementitious stabilised materials.

Where a stabilised layer is to be placed on the surface of a granular pavement or bituminous sealed pavement, the Contractor shall carry out the works detailed in this clause and Clause 8.8.9.3.

#### **Witness Point 3**

Where a stabilised layer is to be placed on the surface of a foamed bitumen stabilised pavement, the Contractor shall carry out the works detailed in this clause and Clause 8.8.9.4. **Witness Point 3**

For all surfaces, preparation shall include the removal of all foreign and loose material with a road broom.

Unsound materials shall be removed and disposed of as agreed with the Administrator. Where there is a dispute about what constitutes unsound materials and / or their extent they shall be as determined by the Administrator. The unsound materials shall be replaced with a like material as approved by the Administrator.

For instance, unless otherwise directed by the Administrator:

- a) Unsound foamed bitumen stabilised material shall be replaced with an appropriate, corresponding foamed bitumen stabilised material that complies with this Technical Specification.
- b) Unsound asphalt shall be replaced with an appropriate, corresponding mix type that complies with MRTS30 *Asphalt Pavements*, or foamed bitumen stabilised material that complies with this Technical Specification.
- c) Unsound cementitious stabilised or modified material shall be replaced with an appropriate, corresponding mix type that complies with MRTS08 *Plant-Mixed Heavily Bound (Cemented) Pavements*, or foamed bitumen stabilised material that complies with this Technical Specification, and
- d) Unsound unbound granular material shall be replaced with a corresponding type that complies with MRTS05 *Unbound Pavements*.

All unsuitable, unsound, foreign and / or loose material generated from the preparatory works shall be removed from the road formation and utilised / disposed of in accordance with the requirements of Clause 10 of MRTS01 *Introduction to Technical Specifications*.

## 8.8.9.2 Preparation of bound pavement or concrete surface

### 8.8.9.2.1 General

The surface of the pavement or substrate shall be dry and thoroughly mechanically swept using a rotary broom to remove any foreign, loose material or other deleterious material that may be present.

Any deleterious material that still adheres to the surface after sweeping shall be removed by other means without damaging the pavement or substrate. Any damage caused by the removal of such materials shall be rectified to the satisfaction of the Administrator at the Contractor's expense.

In addition to and following mechanical sweeping:

- a) Areas of oil or fuel spillage shall be cleaned with detergent, flushed with clean water and allowed to dry prior to application of the tack coat, and
- b) Cracks, joints or holes in the pavement / bridge deck shall be rectified as stated in Clauses 8.8.9.2.2 and 8.8.9.2.3.

Frames for manhole covers, gully gratings, kerbs and other structures shall have the joint surfaces cleaned so that they are free of any extraneous material.

### 8.8.9.2.2 Crack filling

In the areas shown in the drawings or stated in Clause 15 of Annexure MRTS09.1, cracks wider than 2 mm shall be filled prior to placement of any stabilised material / layer.

The Contractor shall mark out, in the presence of the Administrator, the extent of crack filling to be carried out. **Hold Point 8**

The cracks to be filled shall be cleaned before they are filled.

Cracks shall be filled level with the surrounding surface with a polymer modified sealant approved by the Administrator.

### 8.8.9.2.3 Strain alleviating geotextile strips

In the areas shown on the drawings or stated in Clause 16 of Annexure MRTS09.1, strain alleviating geotextile strips shall be applied to existing cracks prior to placement of any stabilised material / layer. The contractor shall mark out, in the presence of the Administrator, the extent of the strain alleviating geotextile strips to be applied. **Hold Point 9**

Strain alleviating geotextile strips shall be non-woven polyester geotextile pre-coated with a rubberised bitumen adhesive base.

Prior to application of the geotextile strips, the existing surface shall be swept clean and shall be free of dust, grit, surface moisture and vegetation. Further, any cracks or joints wider than 2 mm shall be filled in accordance with the requirements of Clause 8.8.9.2.1.

The surface to which any strain alleviating geotextile strip is to be applied shall be sprayed with a bituminous emulsion tack coat at a rate of 0.25 L/m<sup>2</sup>, unless otherwise directed by the Administrator. Alternatively, a proprietary primer that is recommended by the manufacturer of the strain alleviating geotextile strips may be used.

The strain alleviating geotextile strips shall be laid to cover a minimum width of 250 mm (nominally 125 mm on each side of the crack). Placement of the strain alleviating geotextile strips shall be carried where:

- a) pavement temperature is not less than 15°C and rain is not likely to fall prior to the completion of the installation, and
- b) pavement surface is clean and dry.

Joints in the strain alleviating geotextile strips shall be overlapped in accordance with the manufacturer's recommendations.

After placement, the strain alleviating geotextile strips shall be rolled with at least one pass of a pneumatic-tyred roller to ensure proper adhesion. The strain alleviating geotextile strips shall be placed free of wrinkles or creases.

Traffic shall not be permitted to traverse the strain alleviating geotextile strips for at least 20 minutes after rolling.

#### **8.8.9.3 Preparation of granular pavement surface or bituminous sealed pavement**

Where a stabilised layer is to be laid over pavement with a bituminous surfacing, the bituminous surfacing shall be lightly scarified or pre-milled.

The Contractor shall ensure the surface onto which a stabilised layer is to be constructed is well compacted, trimmed and prepared before material for the overlying stabilised layer is placed. Proof rolling shall be carried out in accordance with Test Method Q723.

Where perceptible surface deformation is observed under proof rolling, construction of the stabilised layer shall not proceed until works are undertaken to eliminate all perceptible surface deformation under proof rolling.

The prepared surface shall be swept with a road broom until the larger particles in the surface of the pavement are slightly exposed but ensuring excessive erosion of the surrounding finer material does not occur.

#### **8.8.9.4 Preparation of a foamed bitumen stabilised layer surface prior to the placement of the next foamed bitumen stabilised layer**

##### **8.8.9.4.1 General**

Where a plant-mixed foamed bitumen stabilised layer is to be overlaid directly with another plant-mixed foamed bitumen stabilised layer, the finished surface of the underlying plant-mixed foamed bitumen stabilised layer shall be prepared by either:

- Hard-cut of the surface (refer to Clause 8.8.9.4.2), or
- Class 170 spray seal interlayer (refer to Clause 8.8.9.4.3).

The surface preparation methodology shall be stated in Clause 17 of Annexure MRTS09.1, where no indication is given, a hard-cut of the surface shall be undertaken.

#### 8.8.9.4.2 Hard-cut

The finished surface of the underlying plant-mixed foamed stabilised layer shall be hard-cut:

- after the completion of compaction, and
- within the same work shift as the material was placed.

Cutting back the surface shall uniformly remove a lens of material across the full width of the stabilised layer to produce a roughly textured surface. Scratching or marking the surface is not sufficient. A rough surface texture shall be maintained until such time that the next stabilised layer is placed on top. Hard-cut shall be performed by a grader (with a straight blade, serrated blade or toothed blade) as illustrated in Figure 8.8.9.4.2(a). The hard-cut shall not be performed by a rotary broom. A rotary broom shall be used to remove excessive loose material from the surface once the hard-cut is completed.

All hard-cut material shall be disposed of in accordance with Clause 10 of MRTS01 *Introduction to Technical Specifications*. No separate or additional payment shall be made by the Principal for the removal and disposal of material cut to waste.

Curing and maintenance of the plant-mix foamed bitumen layer shall be undertaken in accordance with the requirements of Clauses 8.8.18 and 8.8.19.

**Figure 8.8.9.4.2(a) – Hard-cut of surface with a grader**

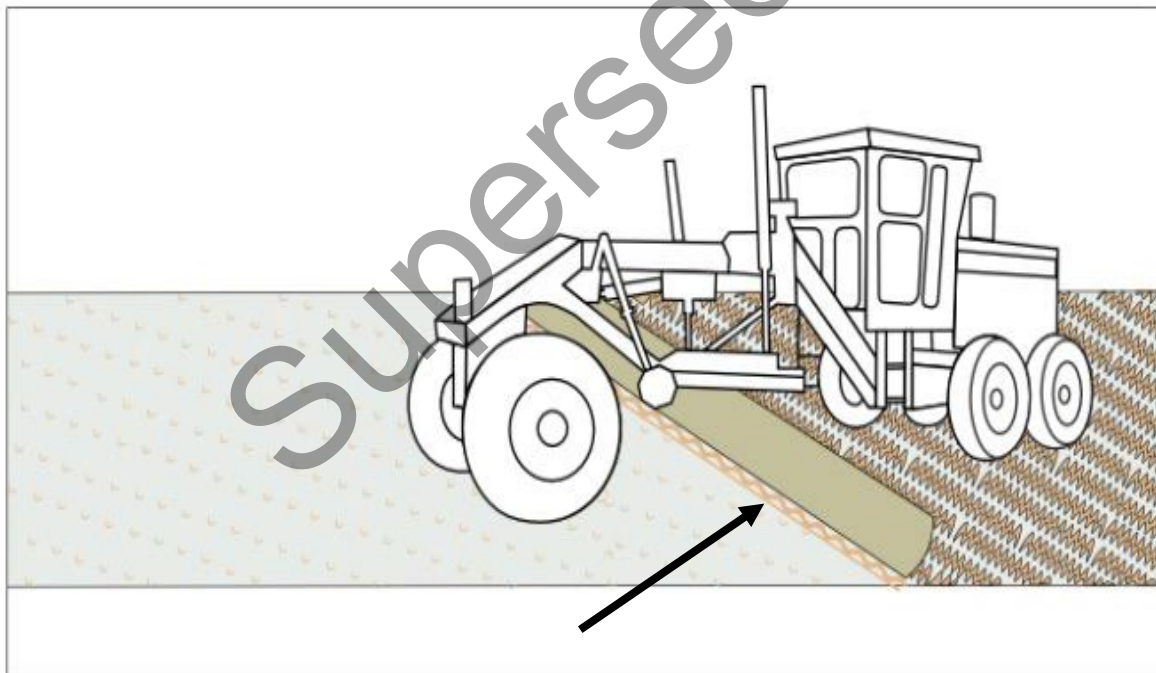

Hard-cut of a smooth surface prior to placing the overlying plant-mixed foamed bitumen stabilised materials creates a rough texture to facilitate the bonding of multiple plant-mix foamed bitumen stabilised layers together. The hard-cut shall be undertaken after completion of compaction. This may occur within the same work shift or the following day. The hard-cut can be performed outside the allowable working time.

Alternative hard-cut methods using plant other than a grader (such as a profiler or profiling attachment) may be considered by the Contractor. The achieved surface texture shall be equivalent (or better) than a hard-cut performed by a grader. The Contractor may present and demonstrate an alternative hard-cut methodology to the Administrator for consideration.

**Figure 8.8.9.4.2(b) – Example of an acceptable hard-cut surface**



#### **8.8.9.4.3 Class 170 spray seal interlayer**

A Class 170 bitumen (C170) 10 mm spray seal interlayer shall be applied to the finished surface of the underlying plant-mixed foamed bitumen stabilised layer.

C170 bitumen binder shall be uniformly sprayed at an indicative spray rate of 1.0 l/m<sup>2</sup>. No cutter shall be added to the C170 binder.

10 mm cover aggregate shall be spread at an indicative spread rate of 160 m<sup>2</sup>/m<sup>3</sup>.



The cover aggregate spread rate needs to be 'light' to leave sufficient 'windows' in the finished mat to allow for good interlock between the spray seal and the overlying plant-mixed foamed bitumen stabilised layer, but not resulting in 'pickup' of the bitumen binder by construction traffic.

The seal design and construction requirements shall be in accordance with the MRTS11 *Sprayed Bituminous Treatments (Excluding Emulsion)*, and relevant departmental Technical Notes and Guidelines.

The spray and spread rates shall be confirmed by the Administrator based on actual test results for the 10 mm cover aggregate to be used for the seal.

Curing and maintenance of the underlying plant-mix foamed bitumen layer shall be undertaken in accordance with the requirements of Clauses 8.8.18 and 8.8.19 until the C170 spray seal interlayer has been applied.

Superseded

The intent of this seal is to facilitate bonding between multiple plant-mix foamed bitumen stabilised layers. The Contractor may elect to utilise cover aggregate larger than 10 mm (such as 14 mm) to provide greater protection of the pavement from the impacts of construction traffic, wet weather or any other temporary circumstances.

Using a C170 spray seal interlayer provides a significant construction advantage as it reduces plant-mix foamed bitumen wastage. Other advantages also include:

- a reduction in water curing (as water curing is not required after the lower PMFB layer has been sealed), and
- protection of the lower PMFB layer from construction traffic and/or wet weather.

**Figure 8.8.9.4.3 – Core showing the C170 spray seal interlayer bonding plant-mixed foamed bitumen stabilised layers together**



### 8.8.10 Layer thickness

Individual compacted layer thicknesses shall be chosen to suit the construction process and the requirements of the Contract. Unless otherwise approved by the Administrator, the compacted layer thicknesses shall be in accordance with Table 8.8.10.

Stabilised layer thicknesses which are greater than the specified maximum limit shown in Table 8.8.10 shall be constructed in multiple layers. Where multiple layers are placed, each layer shall be of equal thickness, unless otherwise approved by the Administrator.

Except in batters, each stabilised layer shall be constructed in a uniform thickness, unless otherwise approved by the Administrator.

**Table 8.8.10 – Layer thickness requirements**

Material	Minimum value (mm)	Maximum value (mm)
Plant-mixed foamed bitumen stabilised layer	125	300

### 8.8.11 Placement

The stabilised material shall be produced, transferred and spread in one concurrent operation.

Where it is placed using a paver, each individual layer shall be placed in one pass that meets the requirements of this Technical Specification without the addition of extra material(s) except as detailed in Clause 8.8.8.

Where the stabilised material is placed using a grader, it shall be manned by a final trim operator.

After placement, the layer shall be compacted and trimmed in accordance with this Technical Specification to produce a tight dense surface that has properties that are within the required tolerances.

### 8.8.12 Compaction

Compaction shall be completed within the allowable working time (refer to Clauses 8.4, 8.5 and 8.6). This shall be carried out using an appropriate roller(s) that is capable of achieving relatively uniform compaction over the depth of each stabilised layer. The stabilised layer shall be compacted to the requirements specified in Clause 8.9.4.

The required rollers for each individual layer thickness are described in Table 8.8.12. The Contractor shall achieve the required minimum characteristic value of the relative compaction results in accordance with Clause 8.9.4.

**Table 8.8.12 – Minimum roller requirements at pavement layer thickness**

Minimum Roller Requirements	Compacted Layer Thickness Range	
	Minimum (mm)	Maximum (mm)
Smooth drum and multi-tyre	125	200
Pad foot, smooth drum and multi-tyre	200	300

A stabilised layer with a compacted thickness between 200 mm and 300 mm shall be initially compacted with a pad foot roller. Pad foot marks shall be removed to prevent differential compaction and the pad foot marks reflecting to the surface. The Contractor shall ensure that no marks caused by a pad foot roller remain on the surface. A minimum cut to -100 mm from the Finished Surface Level (FSL) of the stabilised layer is required to completely remove the influence of the pad foot marks and not create a thin false layer when the stabilised material is reinstated.

When removing the pad foot marks, the stabilised material shall not be wasted. Once the pad foot marks have been completely removed, the stabilised material can be reinstated to allow the completion of compaction and trimming.

The Contractor shall use a smooth drum roller and multi tyre roller to complete the finished surface of the stabilised material.



No marks caused by any roller or stabilisation plant shall be left on the surface of the stabilised layer.

The Contractor shall ensure the longitudinal joints including at the road crown are achieved uniform compaction over the depth of the stabilised layer.

### **8.8.13 Trimming after compaction**

Trimming of the pavement, if required, shall be carried out as soon as practicable after compaction of the pavement. Final trimming shall be completed within the allowable working time as specified in Clauses 8.4, 8.5 and 8.6.

All trimming activities shall be undertaken in preparation for the application of an overlaying pavement layer or bituminous surfacing, with the objective of meeting shape and level requirements, and shall involve cutting to waste.

The trimmed surface shall be free from loose pockets, holes, bumps and lenses of material such that it satisfies the Administrator. Notwithstanding this no marks caused by a pad foot or other equipment shall remain on the surface after final trimming.

Localised depressions and rises shall be treated as determined jointly by the Administrator and the Contractor.

Where the multiple stabilised layers are constructed, with a hard-cut, the hard-cut shall be undertaken by a grader on the compacted layer as per Clause 8.8.9.4.2.

All trimming operations, including a hard-cut (refer to Clause 8.8.9.4.2), shall be cut to waste. All material cut to waste shall be removed and disposed of in accordance with Clause 10 of MRTS01 *Introduction to Technical Specifications*. No separate or additional payment shall be made for the removal and disposal of material cut to waste. The cost of all activities associated with the removal and disposal of material cut to waste shall be deemed to be incorporated into the relevant works.

### **8.8.14 Period for placement, compaction and trimming**

Placement, compaction and trimming shall be completed within allowable working times specified in Clauses 8.4, 8.5 and 8.6.

### **8.8.15 Construction joints**

#### **8.8.15.1 General**

Joints shall be constructed such that the material at the joints complies with the requirements of this Technical Specification.

A construction joint shall be deemed fresh when the material on each side of the joint has been stabilised, placed and compacted within the allowable working time (refer to Clauses 8.4, 8.5 and 8.6).

#### **8.8.15.2 Longitudinal joints**

Longitudinal joints shall not be located in the through traffic wheel paths.

Where a fresh longitudinal joint between adjacent runs is to be compacted, the outside 300 mm of material from the first run shall be left uncompacted until the adjacent material is ready for compaction. The joint shall be water cured during this period. When the fresh joint is compacted, the roller shall be partially supported on the portion of the first run that has been previously compacted.

Joints that are not fresh shall be cut back for the full depth of the layer to form a neat clean vertical face. The minimum distance for cutting back into previously compacted material shall be greater of 75 mm and the distance to a point where the stabilised material compliance with this Technical Specification.

Where there is more than one layer of stabilised material the longitudinal joints of each layer shall be offset from the underlying layer's longitudinal joint by a minimum distance of 150 mm.

No separate or additional payment shall be made for the disposal of material cut to waste. The cost of all activities associated with the disposal of material cut to waste shall be deemed to be incorporated into the relevant works items.

#### **8.8.15.3 Transverse joints**

For transverse joints that are not made during the allowable working time, the adjoining section previously stabilised shall be cut back to form a neat clean vertical face for the full depth of the stabilised layer, by the greater of 150 mm and the distance to a point where the stabilised material complies with this Technical Specification.

Where there is more than one layer of stabilised material, the transverse joints of each layer shall be offset from the underlying layer's joint by a minimum distance of 150 mm.

No separate or additional payment shall be made for the disposal of material cut to waste. The cost of all activities associated with the disposal of material cut to waste shall be deemed to be incorporated into the relevant works items.

#### **8.8.16 Joining new work to existing pavements and structures**

Existing pavements shall be excavated as shown or described in the drawings or Contract to provide:

- a) a clean, vertical surface at the joint line against which the stabilised layer / material is to be placed, and
- b) a longitudinal taper such that the minimum layer thickness is as stated in Clause 8.8.10.

The stabilised material shall be compacted so that the completed layer is neatly finished to match adjacent pavements and structures.

#### **8.8.17 Requirement for trafficking stabilised layer**

The Contractor shall provide for and manage traffic in accordance with MRTS02 *Provision for Traffic* and this Technical Specification. Notwithstanding this, the requirements of this Technical Specification shall take precedence over the requirements of MRTS02 *Provision for Traffic*.

Where the average daily ESA is the design lane in the year of opening is 300 or more, apart from necessary construction traffic, no uppermost stabilised layer shall be trafficked until a bituminous surfacing has been applied.

The uppermost stabilised layer may be opened to traffic in an unsealed state with approval of the Administrator after proof rolling (Clause 9.9) where the average daily ESA is the design lane in the year of opening is less than 300. Notwithstanding this, the requirements of Clause 8.8.20 shall apply.

The Contractor shall take all necessary precautions to protect the work from damage until the work has been surfaced with the final wearing course.

The Administrator may allow traffic on an unsealed stabilised layer when considering the following factors:

- Speed restriction – traffic at  $\leq 60$  km/hr posted speed.
- Traffic volumes (ESAs / day) – typical values are shown in this clause.
- Turning movements (for example, intersections and roundabouts) and steep grades – high shear areas will cause damage to an unsealed surface
- Any incoming wet weather – rain may cause a deterioration of the unsealed surface under traffic movements.
- Curing (Clause 8.8.18) and maintenance (Clause 8.8.19) must be considered by the Contractor.
- Skid resistance – after extensive trafficking, the effect of the wheels may reduce skid resistance.

#### **8.8.18 Curing**

Water curing shall commence immediately after the completion of compaction. Layers other than the topmost stabilised layer shall be water cured until covered by successive layer. The topmost stabilised layer shall be water cured until a bituminous surfacing with a cover aggregate as described in Clause 8.8.20 has been applied.

The surfaces and edges of stabilised layers to be water cured shall be maintained in a continuously damp condition, using the occasional application of a uniformly applied fine mist. Water shall be applied in a manner such that slurring of the surface(s) and edge(s), pavement instability, pavement erosion flushing and / or leaching of the stabilising agents are all avoided.

#### **8.8.19 Maintenance of the stabilised layer**

The stabilised layer shall be maintained by the Contractor until a bituminous surfacing with a cover aggregate is applied, until the stabilised layer is covered by another pavement layer or until the Administrator accepts and takes responsibility for that area (whichever is the longer).

The surface of the compacted layer shall be kept moist, in good order, in good condition and free from contamination. Construction and other traffic shall not use the compacted stabilised layer where damage to the surface may occur.

No separate or additional payment shall be made for maintenance of the stabilised layer. The cost of all activities associated with maintenance of the stabilised layer shall be deemed to be incorporated into the relevant work items for the stabilised layer.

#### **8.8.20 Bituminous surfacing**

Unless otherwise approved by the Administrator, a bituminous surfacing with a cover aggregate shall be applied within seven calendar days of the completion of the uppermost stabilised layer.

#### **8.8.21 Conditions under which stabilisation and placement shall not proceed**

The entire stabilisation and placement process shall not proceed:

- a) during rainfall
- b) when rainfall appears to be imminent

- c) during conditions that may result in the work causing nuisance or danger to people, property, or the environment
- d) when the temperature of any feed stockpile, measured 50 mm below the surface of the stockpile, drops below 10°C unless approved by the Administrator to proceed
- e) when the air temperature, measured in the shade, exceeds 40°C
- f) when Relative Moisture Ratio of Feed Stockpile (RMR FSP) is not within the values specified in Clause 8.8.6, unless approved by the Administrator to proceed, or
- g) when Relative Moisture Ratio of Foamed Bitumen (RMR FB) is not within the values specified in Clause 8.9.3, unless approved by the Administrator to proceed.

## **8.9 Product standards**

### **8.9.1 General**

Compliance testing of the stabilised layer shall be undertaken for each lot. Where a process standard is specified (refer to Clause 8.7.1) the compaction requirements in Clause 8.9.4 shall apply to the trial section(s) but not to other sections. Where a product standard is specified (refer to Clause 8.7.1) the compaction requirements in Clause 8.9.4 shall apply to all lots.

### **8.9.2 Stabilising agent contents**

#### **8.9.2.1 Ordered contents**

At least 14 days prior to the commencement of stabilisation works, the Administrator shall confirm or adjust the bitumen and estimated secondary stabilising agent contents stated in Clause 8 of Annexure MRTS09.1.

The secondary stabilising agent content shall not be less than 1.25% of the dry mass density of the material to be stabilised.

The confirmed or adjusted stabilising agent contents shall be defined as the ordered bituminous stabilising agent content and ordered secondary stabilising agent content. **Milestone**

#### **8.9.2.2 Actual stabilising agent contents**

The actual bituminous and secondary stabilising agent contents shall be represented by the reported values of the stabilising agent contents determined in accordance with Clause 9.5 and Clause 9.6 respectively.

The actual bituminous stabilising agent spread rate shall be within -5% and +10% of the ordered bituminous stabilising agent spread rate specified in Clause 8.9.2.1.

The actual secondary stabilising agent spread rate shall be within  $\pm 10\%$  of the ordered secondary stabilising agent spread rate specified in Clause 8.9.2.1.

The Contractor shall be liable for materials used that are more than the ordered stabilising agent content plus 10%.

### **8.9.3 Relative Moisture Ratio Foamed Bitumen (RMR FB)**

Unless otherwise approved by the Administrator, water shall be added by means of a controlled pressure feed distribution system located inside the mixing chamber of mixing equipment.

The relative moisture ratio of the foamed bitumen stabilised material (RMR FB) shall be determined in accordance with Clause 9.8, and shall comply with the requirements specified in Table 8.9.3.

**Table 8.9.3 – Relative moisture ratio requirements**

Property	Minimum value (%)	Maximum value (%)
Relative moisture ratio of the foamed bitumen stabilised material (RMR FB)	60	80

#### 8.9.4 Compaction standard

The minimum characteristic value of the relative compaction results for the full thickness of the stabilised layer shall be as stated in Clause 5 of Annexure MRTS09.1 or, where not so stated, shall not be less than the value specified in Table 8.9.4.

**Table 8.9.4 – Compaction requirements**

Layer	Minimum relative compaction value
Foamed bitumen stabilised layer	102% (standard compaction)

#### 8.9.5 Geometrics

##### 8.9.5.1 General

The stabilised layer(s) shall be constructed so as not to depart from the alignment, widths, thicknesses, lengths, heights and shapes specified in the Drawings or Contract by more than the tolerances stated in Clauses 8.9.5.2 to 8.9.5.5.

When constructing the stabilised layer, the Contractor shall consider the geometric tolerances of any overlying layer(s) and shall prepare the stabilised layer in such a manner that will permit the geometric conformance of the stabilised layer, and any overlying layer(s).

##### 8.9.5.2 Geometrics, vertical tolerances

###### 8.9.5.2.1 Milling tolerance

The actual depth of milling as specified in Clause 8.8.2 at any point shall not be less than the specified depth, and shall not be greater than the specified depth plus 10 mm.

###### 8.9.5.2.2 Primary tolerance

A primary tolerance shall apply to the height of any point on the surface of the topmost stabilised layer.

The primary tolerance shall be as stated in Clause 6.1 of Annexure MRTS09.1 as one of the alternatives in Table 8.9.5.2.2. If no indication is given, the primary tolerance shall be Alternative B (-5 to +15 mm).

**Table 8.9.5.2.2 – Primary tolerance for stabilised layers**

Alternative	Primary Tolerance (mm)
A	-5 to +10
B	-5 to +15
C	Thickness Only

Alternative A (-5 to +10 mm) is recommended for the stabilised layer when the subsequent overlying layer is asphalt.

In all cases the nominated primary tolerance shall also apply to the thickness of a completed stabilised layer (refer to Clause 8.9.5.3.1).

### 8.9.5.3 Geometrics, thickness tolerance

#### 8.9.5.3.1 General

The thickness of the compacted stabilised layer shall be stated in Clause 8 of Annexure MRTS09.1, or otherwise shown in the Drawings.

At any point of the completed stabilised layer, the measured actual stabilised layer thickness (refer to Clause 8.9.5.3.2) shall be within the primary tolerance nominated in Clause 8.9.5.2.2 of the design thickness specified in the Contract or Drawings.

Where multiple stabilised layers are constructed in the pavement structure, the thickness tolerance of the total stabilised layers shall be not less than -5 mm at any point.

Where a completed stabilised layer is required to be hard-cut in accordance with Clause 8.8.9.4.2 prior to the overlay of the next layer of stabilised material, the thickness tolerance of the lower layer may be reduced to  $\pm 10$  mm at the Administrator's discretion to allow for the successful completion of the hard-cut.

#### 8.9.5.3.2 Measuring actual stabilised layer thickness

The minimum characteristic value of all stabilised layer thickness measurements for each lot shall be calculated in accordance with Clause 12 of MRTS01 *Introduction to Technical Specifications* and reported to the Administrator (rounded to the nearest 1 mm).

#### 8.9.5.4 Geometrics, horizontal tolerances

The horizontal position of any point on the pavement or the edge of any milling shall not differ from the corresponding point shown on the drawings or as otherwise specified in the Contract, calculated as described in Clause 8.9.5, by more than  $\pm 50$  mm, except where alignment of the pavement with an existing pavement or structure is necessary.

In this case, the new work shall be joined neatly to the existing work or structure in a smooth manner as shown on the drawings or as otherwise specified in the Contract. If the drawings or other Contract documents do not show, describe or specify how new work is to join to existing pavement or structures then it shall be done in a manner that is acceptable to and approved by the Administrator.

### 8.9.5.5 Additional tolerances

#### 8.9.5.5.1 General

Additional tolerances shall apply to the pavement lots in the topmost stabilised layer and the other stabilised layers specified in Clause 6.2 of Annexure MRTS09.1. For such lots the additional tolerances specified in Clauses 8.9.5.5.2, 8.9.5.5.3 and 8.9.5.5.4 shall apply.

The Contractor may have to carry out additional work to achieve these additional tolerances. No additional payment shall be made by the Principal for achieving such additional tolerances. Payment for any such work shall be deemed to be included in the Contractor's scheduled rate for the relevant items.

#### 8.9.5.5.2 Deviation from a straightedge

The deviation from a 3 m long straightedge placed anywhere on the surface of any layer to which this additional tolerance applies, shall not exceed the limit stated in Clause 6.3 of Annexure MRTS09.1, due allowance being made for design shape, where relevant. The limit stated in Clause 6.3 of Annexure MRTS09.1 shall be one of the alternatives given in Table 8.9.5.5.2. If no limit is given, it shall be Alternative D (5 mm).

**Table 8.9.5.5.2 – Tolerance for deviation from a straightedge**

Alternative	Maximum value (mm)
D	5
E	8
F	15

#### 8.9.5.5.3 Crossfall

The crossfall of any stabilised layer shall not depart from the corresponding crossfall shown in the Contract by more than 0.5% absolute.

The crossfall shall be measured:

- a) Between any two points more than 2 m apart except where a pavement verge is less than two metres wide. For pavement verges less than two metres wide, the measurement shall be made between the extreme edges of the pavement verge on each side of the pavement.
- b) Transverse to the centre line of the carriageway, and
- c) Within the boundaries of a cross-section element that has a constant crossfall.

#### 8.9.5.5.4 Road roughness (surface evenness)

Clause 6.4.1 of Annexure MRTS09.1 specifies whether a surface evenness tolerance applies to the final (upper most) stabilised layer. If no indication is given, surface evenness tolerance shall apply.

The surface evenness of the final (uppermost) stabilised layer to which this additional tolerance applies shall be such as to provide a road roughness value not exceeding the specified road roughness ( $R_s$ ) stated in Clause 6.4.2 of Annexure MRTS09.1 or, where not so stated, not exceeding the value specified in Table 8.9.5.5.4.

**Table 8.9.5.5.4 – Road roughness requirements**

Property	Maximum value (m/km)
Road roughness ( $R_s$ )	1.94

The roughness of the following features is required to be reported during roughness testing, but shall be excluded from the ride quality assessment:

- roundabouts
- railway crossing and grids
- bridge joints, and
- inspection pit covers (for example, drainage access chambers).

The Contractor shall nominate a methodology and provide calculations on ride quality for the Administrators acceptance, showing how each feature has been excluded from the assessment and the subsequent lot structure.

Pavement features (including joints) or signalised / unsignalized intersections (other than roundabouts) shall not be excluded from the ride quality assessment unless agreed by Administrator.

The Administrator may increase the specified maximum road roughness ( $R_s$ ) value to 2.31 m/km when the stabilised layer will be overlaid with asphalt or another pavement material within the same Contract, and there is a roughness requirement specified elsewhere in the Contract for the overlying layer.

In all cases, when applying *extended limits* and *reduced values* in accordance with MRS09, the specified maximum road roughness ( $R_s$ ) value shall be as stated in Clause 6.4.2 of Annexure MRTS09.1 or, where not so stated, not exceeding the value specified in Table 8.9.5.5.4.

## 9 Construction compliance testing

### 9.1 General

Unless otherwise stated in this Technical Specification, the selection of sampling or test locations shall be carried out using random stratified sampling. Exceptions include testing of:

- a) geometrics (Clause 9.4)
- b) the bituminous stabilising agent content (Clause 9.5)
- c) the secondary stabilising agent content (Clause 9.6)
- d) proof rolling of pavement layers (Clause 9.9).

The Contractor is responsible for performing sufficient tests to ensure that the pavement complies with the standards and requirements of this Technical Specification. However, the Contractor's testing program shall be such that the testing frequencies and number of tests are not less than those specified in Clause 5.4.



## 9.2 Process requirements

Where construction has been carried out using process requirements, checking for compliance with the specified requirements shall be carried out during and after the construction operation, as relevant. Except for compaction, compliance checking shall be carried out in accordance with Clause 5.4. If a process requirement is specified for compaction, the minimum testing frequencies and minimum number of tests for compaction specified in Clause 5.4 apply to trial sections and do not apply to other sections.

Notwithstanding this, the requirements of Clause 8.7.2 shall apply.

## 9.3 Product standards

Where construction has been carried out using product standards, compliance testing of the pavement shall be undertaken for each lot.

If a product standard is specified, the minimum testing frequencies and minimum number of tests for compaction specified in Clause 5.4 apply.

Notwithstanding this, the requirements of Clause 8.7.3 shall apply.

## 9.4 Geometrics

### 9.4.1 General

All geometric tolerances, except for surface evenness as specified in Clause 9.4.2, shall be checked at regular intervals not greater than those specified in Clause 5.4.

### 9.4.2 Road roughness (surface evenness)

The surface evenness of a stabilised layer shall be measured by road roughness as per Test Method Q708B, Q708C and Q708D.

For road roughness testing, a lot shall be 100 m in length.

## 9.5 Bituminous stabilising agent content

The bituminous stabilising agent content (%) shall be recorded in accordance with frequencies stated in Table 5.4. The actual bituminous agent content shall be calculated by comparing the total mass of bitumen at 15°C used, against the total converted dry mass of all foamed bitumen stabilised material produced and weighed over the calibrated weighbridge or approved secondary weighing device.

The converted dry mass shall have subtracted the total mass of bitumen used, the total mass of secondary stabilising agent used, and the average moisture content of the foamed bitumen stabilised material.

$$\text{Bituminous stabilising agent content (\%)} = \frac{\frac{M_B}{1000}}{\left( M_T - \left( \left( M_T - \frac{100 \times M_T}{100 + W} \right) + \frac{M_L}{1000} + \frac{M_B}{1000} \right) \right)} \times 100$$

where:

$M_B$  = total mass of bitumen at 15°C (kg) (calculation provided below)

$M_T$  = total mass of all stabilised materials produced (tonnes)

$W$  = average moisture content of the foamed bitumen stabilised material (%), and

$M_L$  = total mass of secondary stabilising agent (kg).

The mass of bitumen measurements shall be taken from the bitumen tanker (or storage vessel) using dip readings or other method approved by the Administrator.

In all cases the actual bituminous stabilising agent content shall be within the allowable tolerance specified in Clause 8.9.2.2.

All measurements shall be recorded and included in the quality records and reported to the Administrator. The record and report for each measurement per lot shall include:

- a) where the measurement was taken and the date and time of the measurement
- b) the average moisture content of the stabilised material in accordance with Clause 9.7 and Clause 8.9.3.
- c) the extents and dimensions of placement and construction
- d) the date and time of the start and end of production
- e) the total quantity (including any excess and / or wastage) of stabilised material produced between each measurement and / or during the whole period of production (weighed over the calibrated weighbridge or approved secondary weighing device)
- f) the quantity of bituminous stabilising agent incorporated into the material between each measurement and / or during the whole period of production
- g) the foaming properties of the bituminous stabilising agent at the start of production and at the addition of any bitumen to a tanker
- h) amount and added time of foaming agent, and
- i) the temperature of the bituminous stabilising agent in the tanker at the start and during production.

All records shall be such that the actual bituminous stabilising agent content for each lot and production shall be calculated at 15°C before production recommences.

All volume conversions, in relation to changes in temperature of bituminous materials shall be carried out in accordance with the relevant factors listed in Table 9.5 using the following formula:

$$V_B = V_{BH} \times F_T$$

where:

$V_B$  = volume of bitumen at 15°C (L)

$V_{BH}$  = volume of bitumen at high temperature (L) immediately prior to incorporation into the materials to be stabilised, and

$F_T$  = factor in high temperature from Table 9.5

The mass of bitumen is then calculated from the volume of bitumen at 15°C using the following formula:

$$M_B = V_B \times 1.04$$

where:

$M_B$  = mass of bitumen at 15°C (kg), and

$V_B$  = volume of bitumen at 15°C (L)

**Table 9.5 – Equivalent volumes at 15°C of 1 litre of bituminous material measured at higher temperatures**

Temp (°C)	Factor	Temp (°C)	Factor	Temp (°C)	Factor
15	1	80	0.9597	145	0.9207
20	0.9969	85	0.9566	150	0.9177
25	0.9938	90	0.9536	155	0.9148
30	0.9907	95	0.9506	160	0.9118
35	0.9876	100	0.9476	165	0.9089
40	0.9844	105	0.9446	170	0.906
45	0.9813	110	0.9416	175	0.9031
50	0.9782	115	0.9385	180	0.9002
55	0.9751	120	0.9355	185	0.8973
60	0.972	125	0.9326	190	0.8945
65	0.9689	130	0.9296	195	0.8916
70	0.9658	135	0.9266	200	0.8888
75	0.9627	140	0.9236	205	0.886

### 9.6 Secondary stabilising agent content

The secondary stabilising agent content (%) shall be recorded in accordance with frequencies stated in Table 5.4. The actual secondary stabilising agent content shall be calculated by comparing the total mass of secondary stabilising agent used, against the total converted dry mass of all foamed bitumen stabilised material produced and weighed over the calibrated weighbridge or approved secondary weighing device.

The converted dry mass shall have subtracted the total mass of bitumen used, the total mass of secondary stabilising agent used, and, the average moisture content of the foamed bitumen stabilised material.

$$\text{Secondary stabilising agent content (\%)} = \frac{\frac{M_L}{1000}}{\left( M_T - \left( \left( M_T - \frac{100 \times M_T}{100 + W} \right) + \frac{M_L}{1000} + \frac{M_B}{1000} \right) \right)} \times 100$$

where:

$M_L$  = total mass of secondary stabilising agent (kg)

$M_T$  = total mass of all stabilised materials produced (tonnes)

$W$  = average moisture content of the foamed bitumen stabilised material (%), and

$M_B$  = total mass of bitumen at 15°C (kg) (calculation provided in Clause 9.5).

The mass of secondary stabilising agent measurements shall be taken from the silo load cells.

In all cases the actual secondary stabilising agent content shall be within the allowable tolerance specified in Clause 8.9.2.2.

All measurements shall be recorded and included in the quality records and reported to the Administrator. The record and report for each measurement per lot shall include:

- a) where the measurement was taken and the date and time of the measurement
- b) the extents and dimensions of placement and construction
- c) the date and time of the start and end of production
- d) the quantity of stabilised material produced between each measurement and during the whole period of production
- e) the quantity of secondary stabilising agent incorporated into the material to be stabilised between each measurement and during the whole period of production, and
- f) the average of the actual quantity of material to be stabilised incorporated during production.

### **9.7 Compaction**

The compaction standard for each lot shall be represented by the minimum characteristic value of the compaction results. The characteristic value shall be calculated as stated in Clause 12 of MRTS01 *Introduction to Technical Specifications* or Test Method Q020 using the individual relative compactions determined from testing of each lot.

Where the minimum characteristic value of a lot's compaction results does not comply with the requirements of this specification, the Contractor shall raise a suitable non-conformance report. The Administrator should review each individual compaction result. The review may necessitate the need for additional investigation to identify the underlying cause(s) for the noncompliance. The Administrator should also review the homogeneity of the works.

The locations of all samples taken for the determination of reference density, insitu dry density and relative compaction shall be recorded in accordance with the approved Contractor's quality plan.

Sampling of the stabilised materials shall be undertaken at the plant. Sampling of the stabilised materials to determine the laboratory reference density as detailed in Test Method Q142A shall take place after completing the manufacturing and mixing of the stabilised material, but prior to the commencement of compaction. Selection of sampling locations shall be determined in accordance with Test Method AS 1289.1.4.2 (sampling or testing by time, tonnage or volume). Sampling of the stabilised materials shall be undertaken in accordance with one of the following test methods and techniques:

- a) AS 1141.3.1 Sampling aided by power equipment: *sampling using other than back blading*,
- b) Q060 Sampling during discharge: *moving stream – loader bucket*, or
- c) AS 1141.3.1 Hand sampling procedure: *sampling from trucks*.

The relative compaction of the stabilised material as detailed in Test Method Q140A shall be determined for the entire thickness of the stabilised layer.

Where the Contractor elects to place and compact two layers of stabilised materials in a single shift not exceeding a total thickness of 300 mm, the relative compaction tests Q141A and Q141B may be undertaken for the full depth of the stabilised material.

#### **9.7.1 Time limits for reference density laboratory compaction**

Following sampling, reference density testing shall be completed to a stage where laboratory compaction has been completed within three hours from the mixing of the stabilised materials.

To comply with the above requirements, the Contractor may need to consider the establishment of an annex laboratory facility onsite.

Additionally, following sampling, oven drying of all specimens used to determine the moisture content shall commence within the same work shift as the stabilisation works for the corresponding lot.

#### **9.7.2 Time limits for the determination of compacted density**

Unless otherwise approved by the Administrator, the determination of compacted density using Test Method Q141A or Q141B shall be completed to a stage where the wet density has been determined within 24 hours after the end of the work shift where stabilisation works were completed for the corresponding lot.

Additionally, any moisture sub-sample is being oven dried within the same work shift as the compacted density testing for Test Method Q141A or Q141B is being undertaken.

#### **9.7.3 Time limits for the determination of material biases**

For the determination of material biases for Test Method Q141A, compacted density testing using Test Method Q141B shall be completed to a stage where the wet density has been determined within 24 hours after the end of the work shift where stabilisation works were completed for the corresponding lot.

Additionally, any moisture sub-sample is being oven dried within the same work shift as the compacted density testing for Test Method Q141B is being undertaken.

### **9.8 Relative Moisture Ratio Foamed Bitumen (RMR FB)**

The relative moisture ratio of the stabilised material shall be determined in accordance with Test Method Q250.

The moisture samples of stabilised materials shall be taken in accordance with Clause 9.7 after completing manufacturing and mixing of the stabilised material. Following sampling, oven drying of all specimens used to determine the moisture content shall commence within the same work shift as the stabilisation works for the corresponding lot.

The relative moisture ratio value shall be calculated using the individual moisture content compared to the optimum moisture content for each corresponding location. The minimum testing frequency shall be as per Clause 5.4. The results shall be reported to the Administrator as soon as it is available.

## **9.9 Proof rolling**

### **9.9.1 Proof rolling prior to early trafficking**

No trafficking shall be allowed until the requirement of this Clause 9.9 is carried out and no perceptible surface deformation is observed. Additional curing time may be required prior to traffic.

### **9.9.2 Proof rolling of stabilised layers**

The proof rolling test specified in this clause shall apply to each completed stabilised layer, unless stated otherwise in Clause 7 of Annexure MRTS09.1.

Each stabilised layer shall be tested for perceptible surface deformation by 'proof rolling' the stabilised layer, in the presence of the Administrator **Witness Point 4** All areas of the stabilised layers shall be 'proof rolled', including all trafficked lanes, shoulders and other areas.

Testing shall be in accordance with Test Method Q723 unless otherwise approved by the Administrator. Testing for perceptible surface deformation is exempt from the requirement for NATA accreditation or Construction Material Testing (CMT) registration.

Where the surface of any section of the stabilised layer displays perceptible surface deformation under proof rolling, the Administrator may require the Contractor to carry out additional compliance testing to ensure that the affected section of the stabilised layer complies with Clauses 8.9.2.2, 8.9.3 and 8.9.4. No additional payment shall be made by the Principal for such additional testing.

Where the surface of any section of a stabilised layer displays perceptible surface deformation under proof rolling, the construction of any overlying pavement layer and / or spray seal shall not proceed until the Administrator grants the Contractor permission to proceed in accordance with Clause 9.9.

The proof rolling result reported for any stabilised layer lot shall be representative of the condition of the lot immediately prior to it being covered by another pavement layer or spray seal. If the stabilised layer lot has been subjected to rainfall or moisture ingress in any way since proof rolling was undertaken, the Administrator may direct the Contractor to retest the lot to prove conformance. If the retested results do not comply with the requirements of this Technical Specification, the Contractor shall rectify the stabilised layer such that it complies with the requirements of this Technical Specification. No additional payment will be made by the Principal for any such additional efforts.

Test Method Q723 provides a method for using a loaded water tanker for proof rolling.

Where the Contractor elects to place and compact two (or more) stabilised layers in a single work shift, the proof rolling requirement on the surface of the lower layer(s) may be omitted by the Administrator to allow for the completion of the Works, provided the Contractor meets the following criteria:

- the perceptible surface deformation observed shall not be excessive, and
- each layer of stabilised material is shown to comply with Clauses 8.9.2.2, 8.9.3, 8.9.4, and 8.9.5.

The above shall not apply when overlaying a stabilised layer which is defined in the Contract / drawings as an 'improved layer' or 'working platform'.

### 9.10 Acceptance

For any completed stabilised pavement lot, the Contractor shall submit to the Administrator all compliance testing relevant to that lot (except modulus and CBR test results) within 72 hours after the completion of the lot's final trimming (refer to Clause 8.8.13). Construction shall not proceed until the Administrator has received these compliance test results. The Contractor shall allow at least one working day for a response from the Administrator.

Compliance test results need to be provided by the Contractor to the Administrator in a timely manner (within 72 hours after the completion of the lot's final trimming). This will allow the Contractor and Administrator to monitor the progress and quality of the works and address any non-conformances promptly.

No stabilised pavement lot shall be covered by a subsequent layer of pavement or by a surfacing until all compliance testing has been completed and the layer has been presented to the Administrator for permission to proceed. **Hold Point 10**

No stabilised pavement lot shall be covered by a subsequent layer of pavement or by a surfacing until the As Constructed Survey requirements for the stabilised pavement lot have been met as specified in MRTS56 *Construction Surveying* and notice of such works has been provided to the Administrator.

## 10 Supplementary requirements

Notwithstanding the requirements specified in Clauses 1 to 9 they are varied by the supplementary requirements given in Clause 18 of Annexure MRTS09.1.

**Appendix A: Maximum lot sizes and minimum testing frequencies**

**Table A1 – Maximum lot size requirements**

Construction Activity	Maximum Lot Size
Supply of feed stockpile of UM1 materials to be stabilised (refer to Figure A1(a) and A1(b))	5,000 tonnes
Supply of unbound granular materials for UM2 and UM3 materials to be stabilised (refer to Figure A2)	5,000 tonnes
Supply of reclaimed granular materials for UM2 and UM3 materials to be stabilised (refer to Figure A2)	2,500 tonnes
Supply of feed stockpile of UM2 and UM3 materials to be stabilised (refer to Figure A2)	2,500 tonnes
Construction of plant-mix foamed bitumen pavement	A continuous single layer constructed in 1 day's production
Road roughness (surface evenness) testing	100 m

Superseded



**Figure A1(a) – Schematic of material testing requirements for the supply of UM1 materials which are foamed bitumen stabilised at the same quarry where the granular material is produced**

Quarried granular feed stockpile UM1 materials:

- Refer to Table A1 for maximum lot size
- Refer to Table A2(a) for minimum material testing frequencies.

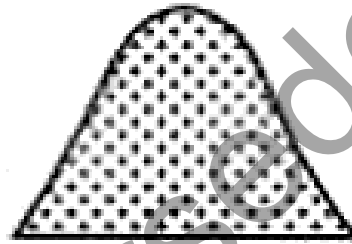

**UNBOUND GRANULAR MATERIAL**

5,000 tonnes stockpile  
(quarry)

**Figure A1(b) – Schematic of material testing requirements for the supply of UM1 materials where the granular material is produced at a quarry, and then transported to a different location for foamed bitumen stabilising**

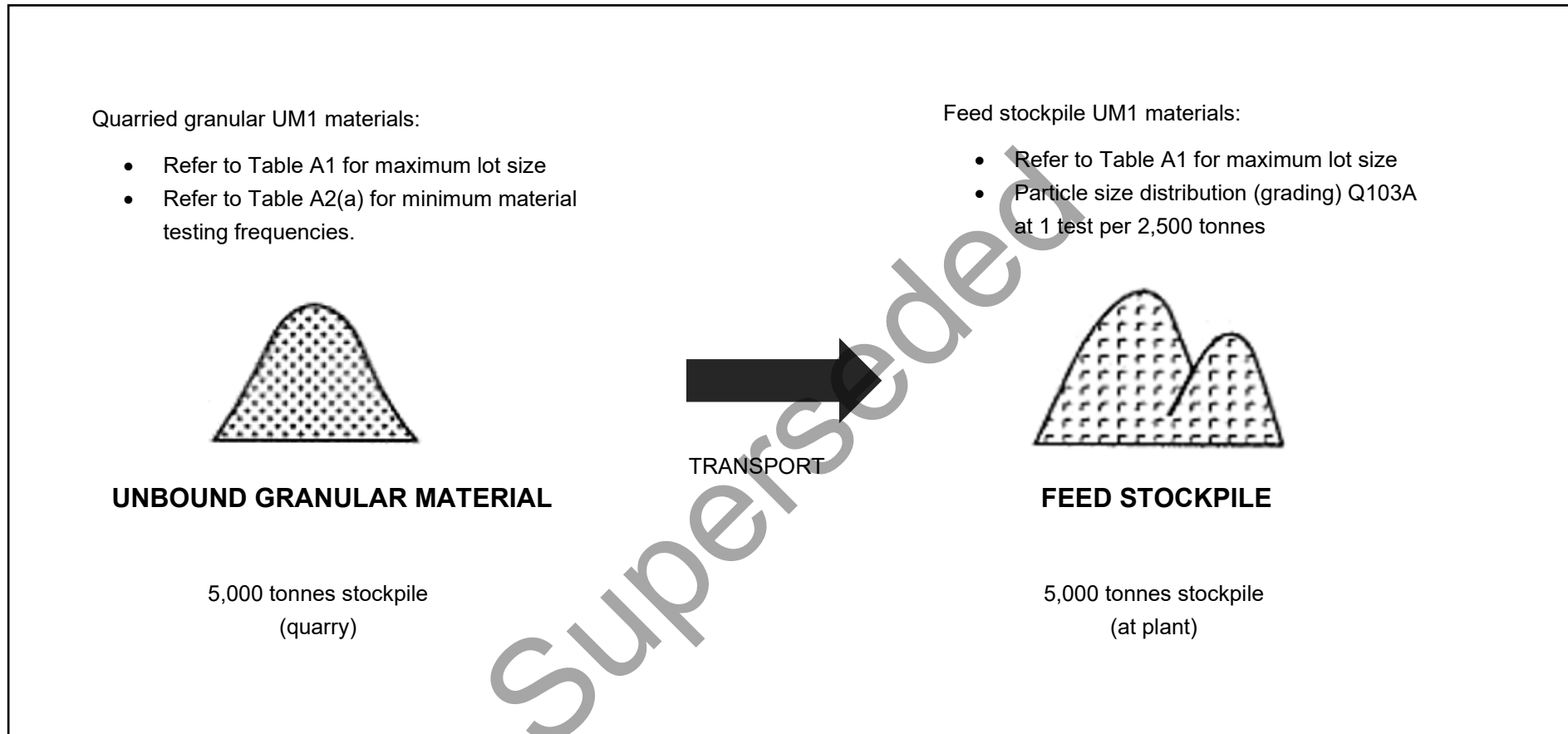

**Table A2(a) – Supply of unbound granular materials for UM1 materials – source and product compliance testing requirements**

Material Property	Test Method	Normal Testing Level		Reduced Testing Level			
		Minimum Testing Frequency	Minimum No. of Tests	Minimum Testing Frequency	Minimum No. of Tests		
<b>Source Testing</b>		Superseded For Type 2 unbound granular materials refer to MRTS05 <i>Unbound Pavements</i>					
Petrographic assessment of aggregates	Q188						
Wet strength	AS 1141.22						
Wet/dry strength variation	AS 1141.22						
Water absorption	AS 1141.6						
Degradation factor	Q208B						
<b>Product Testing</b>							
Flakiness index	Q201						
California Bearing Ratio*	Q113A						
Particle size distribution (grading)	Q103A						
Fines ratio	Q103A						
Liquid limit	Q104A						
Linear shrinkage	Q106						
UCS (Type 2 materials containing recycled concrete)	Q115						
Foreign Material (Type 2 materials containing recycled material)	Q477						
pH (Type 2 materials containing recycled concrete)	AS 1289.4.3.1						
Resilient Modulus (laboratory)	Q139					1 test per material type and mix design	
Resilient Modulus (plant production)	Q139					1 test per material type and mix design	
Sulfate content (water)	AS 1289.4.2.1#					1 test per water source	

Notes:

\* For Type 2.1, 2.2 and 2.3 materials, a minimum CBR (soaked) of 60% is required (refer to Table 6.2.3(a)).

# Or other published or validated classical chemistry technique or instrumentation technique.

**Figure A2 – Schematic of material testing requirements for the supply of UM2 and UM3 materials**

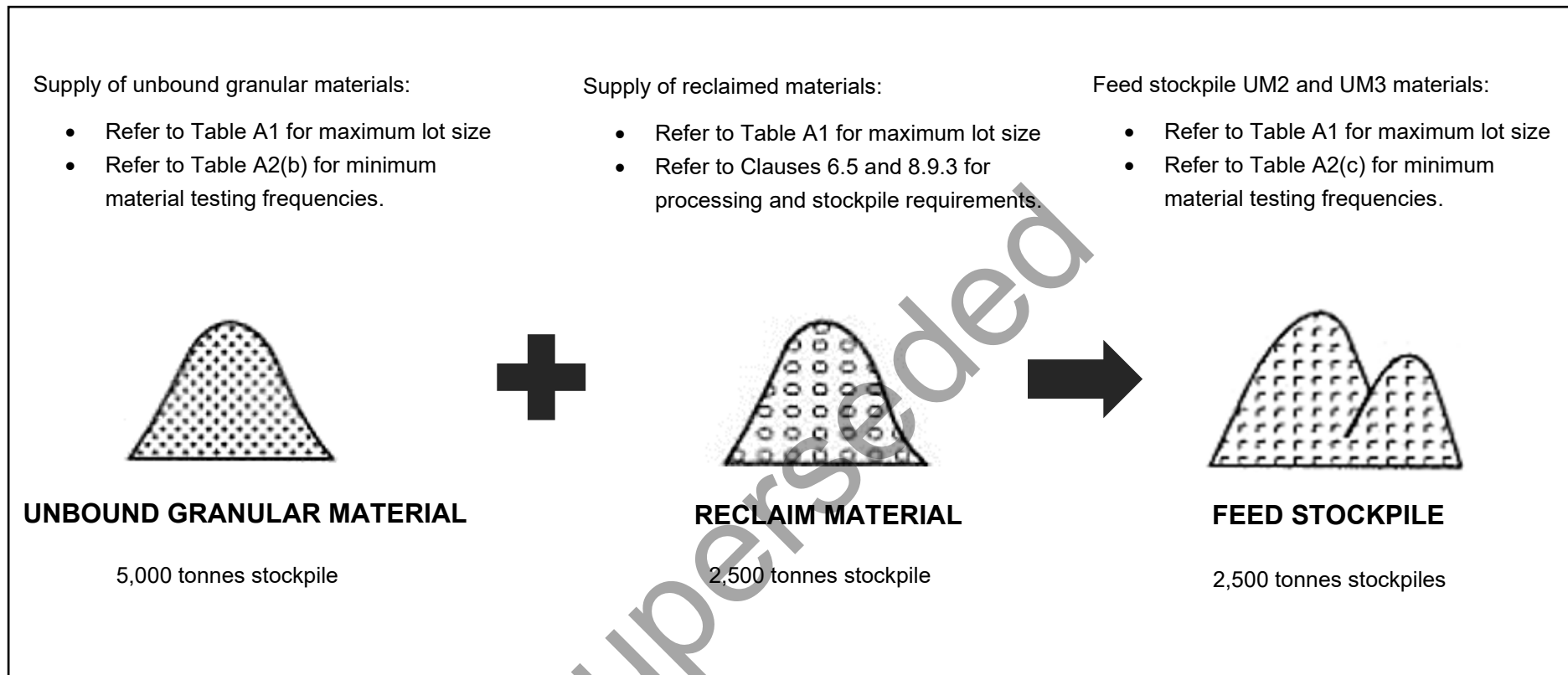

**Table A2(b) – Supply of unbound granular materials for UM2 and UM3 materials – source and product compliance testing requirements**

Material Property	Test Method	Normal Testing Level		Reduced Testing Level	
		Minimum Testing Frequency	Minimum No. of Tests	Minimum Testing Frequency	Minimum No. of Tests
<b>Source Testing</b>					
Petrographic assessment of aggregates	Q188				
Wet strength	AS 1141.22				
Wet/dry strength variation	AS 1141.22				
Water absorption	AS 1141.6				
Degradation factor	Q208B				
<b>Product Testing</b>					
Flakiness index	Q201				
California Bearing Ratio*	Q113A				
Particle size distribution (grading)	Q103A				
Fines ratio	Q103A				
Liquid limit	Q104A				
Linear shrinkage	Q106				
UCS (Type 2 materials containing recycled concrete)	Q115				
Foreign Material (Type 2 materials containing recycled material)	Q477				
pH (Type 2 materials containing recycled concrete)	AS 1289.4.3.1				

For unbound granular materials refer to MRTS05 *Unbound Pavements*

Note:

\* For Type 2.1, 2.2 and 2.3 materials, a minimum CBR (soaked) of 60% is required (refer to Table 6.2.3(a)).

**Table A2(c) – Supply of UM2 and UM3 material – product compliance testing requirements**

Material Property	Test Method	Normal Testing Level		Reduced Testing Level	
		Minimum Testing Frequency	Minimum No. of Tests	Minimum Testing Frequency	Minimum No. of Tests
Particle size distribution (grading)	Q103A	1 test per 1,250 tonnes	2 tests per lot	1 test per 2,500 tonnes	1 test per lot
Fines ratio	Q103A				
Liquid limit	Q104A				
Linear shrinkage	Q106				
Resilient Modulus (laboratory)	Q139	1 test per material type and mix design			
Resilient Modulus (plant production)	Q139	1 test per material type and mix design			
Sulfate content (water)	AS 1289.4.2.1#	1 test per water source			

Note:

# Or other published or validated classical chemistry technique or instrumentation technique.

**Table A3 – Construction compliance testing requirements**

Property	Test Method	Normal Testing Level		Reduced Testing Level	
		Minimum Testing Frequency	Minimum No. of Tests	Minimum Testing Frequency	Minimum No. of Tests
Compaction	Q140A	1 test per 500 m <sup>2</sup>	4 tests per lot	1 test per 1000 m <sup>2</sup>	2 tests per lot
Relative Moisture Ratio of Feed Stockpile (RMR FSP)	Q250	4 tests per lot			
Relative Moisture Ratio of Foamed Bitumen (RMR FB)	Q250	4 tests per lot			
Foamed bitumen properties (half-life and expansion ratio)	Clause 8.8.5	Refer to Table 5.4			
Bituminous stabilising agent content	Clause 9.5				
Secondary stabilising agent content	Clause 9.6				
Resilient Modulus (ex-plant)	Q139	for 0 to 5,000 tonnes of production: 1 test			
		for 5,000 to 15,000 tonnes of production: 1 test			
		for 15,000 to 30,000 tonnes of production: 1 test			
		beyond 30,000 tonnes of production: 1 test per 20,000 tonnes			
Proof Rolling	Q723	Refer to Clause 9.9			

**Table A4 – Geometrics compliance testing requirements**

Property	Test Method	Normal Testing Level		Reduced Testing Level	
		Minimum Testing Frequency	Minimum No. of Tests	Minimum Testing Frequency	Minimum No. of Tests
Geometrics horizontal position	Survey	Each 20 linear metres – measured at all shoulder edges, lane lines and other changes in grade across the pavement			
Geometrics vertical levels	Survey				
Geometrics layer thickness	Survey	1 test per 20 linear m	1 test per 50 linear m		
Deviation from a straightedge	Q712	a) <b>within lane:</b> 1 test per 20 linear metres along each stabilising run, unless otherwise approved by the Administrator. Measurements shall be taken in both the transverse and longitudinal directions. b) <b>longitudinal joint:</b> 1 test per 20 linear metres along each joint, unless otherwise approved by the Administrator. c) <b>transverse joint:</b> 1 measurement per joint in each wheel path in each lane. For the measurement of joints, place the straightedge on the completed layer, perpendicular to the joint. With the end of the straightedge directly over the joint, gradually move the straightedge across the joint for its full length and identify the point on the layer that produces the largest deviation under the straightedge (between two points of contact). Record the deviation at this point. d) <b>joint to existing pavement (not constructed under the Contract):</b> 1 measurement per joint in each wheel path in each lane. For all joints that tie the new works to existing pavement (not constructed under the Contract), place the straightedge on the road surface perpendicular to the joint. With the end of the straightedge directly over the joint and the other end located within the works, record the largest deviation under the straightedge (between two points of contact).			
Crossfall	Survey	1 test per 20 linear metres – measured for all crossfalls shown in the design documentation at the point of testing			
Road roughness (surface evenness)	Q708B, Q708C or Q708D	Refer to Clause 8.9.5.5.4 and Clause 9.4.2			



Superseded