

FRONT ELEVATION

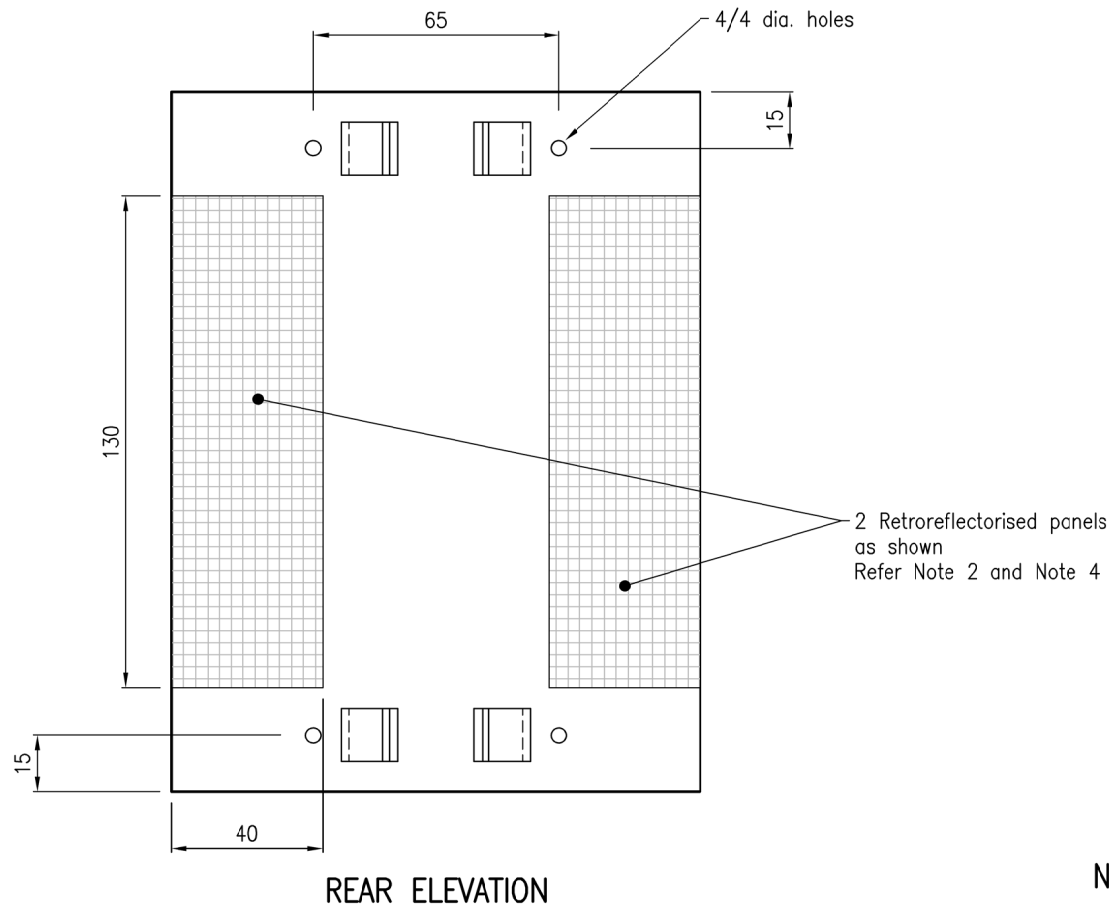

REAR ELEVATION

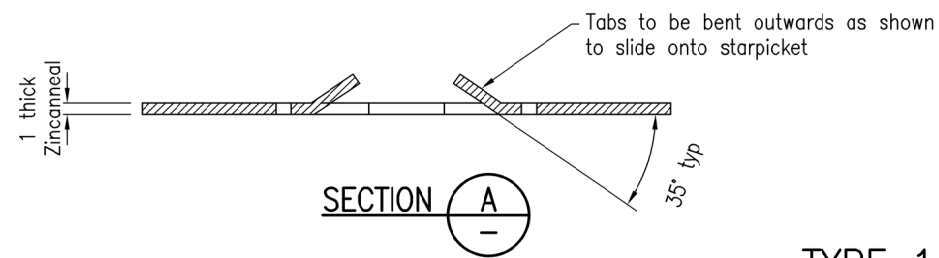

SECTION A

TYPE 1

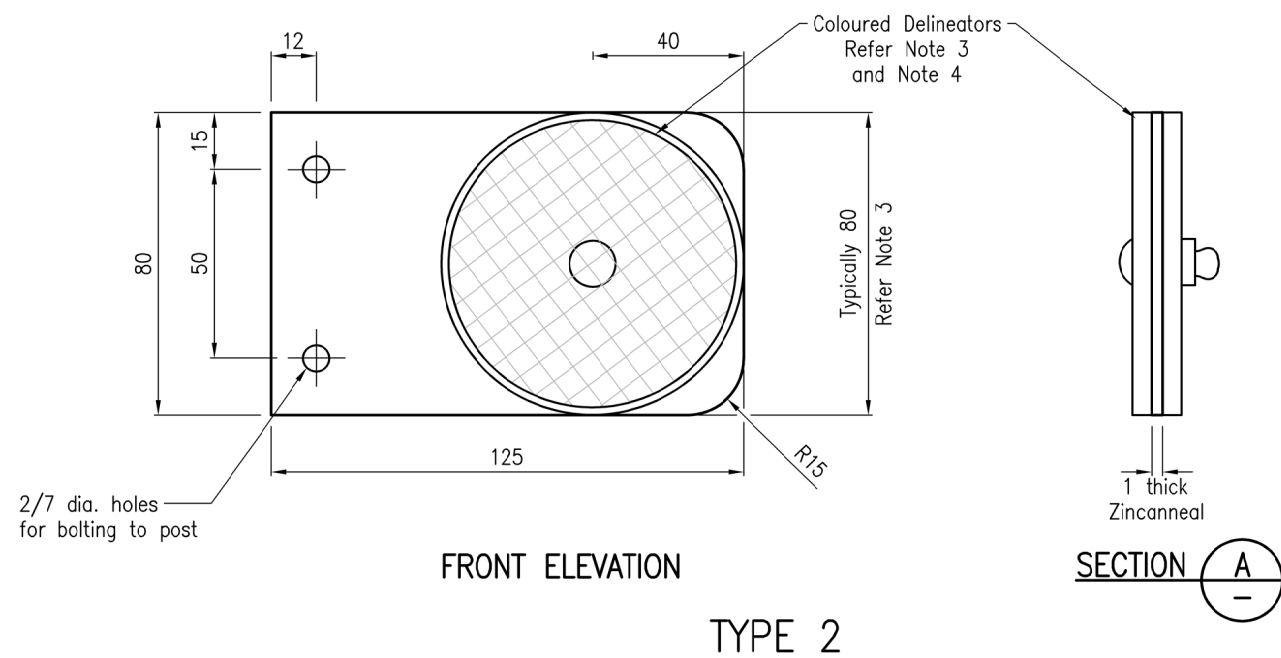

FRONT ELEVATION

SECTION A

TYPE 2

NOTES:

- All steel to be suitably primed and sprayed with white enamel.
- TYPE 1 ONLY**
Retroreflectorised panel to comprise a piece of Class 1A retroreflective sheeting of minimum area 10 000mm² and minimum width 50mm.
- TYPE 2 ONLY**
Delineators to have a maximum area projected in the direction of the intended observer of not more than 10 000mm² including any non-retroreflecting components or surrounds. The shortest projected dimension of the Coloured Delineator is to be 80mm minimum.
- Roadwork delineators to comprise Red Delineators on left-hand-side and White Delineators on right-hand-side (two way roadway) or Yellow Delineators on right-hand-side (one way roadway).
- Dimensions are in millimetres unless shown otherwise.

ASSOCIATED DEPARTMENTAL DOCUMENTS:

- Standard Drawings
- Specifications
- Manual of Uniform Traffic Control Devices (MUTCD)

REFERENCED DOCUMENTS:

- Departmental Specifications:
- MRTS14 Road Furniture

Australian Standards:

- AS/NZS 1906.2: Retroreflective materials and devices for road traffic control purposes – Retroreflective Devices (non-pavement application)

| | | | |
|--|---|--|---------------------|
| Department of Transport and Main Roads | | <small>© The State of Queensland (Department of Transport and Main Roads) 2022 http://creativecommons.org/licenses/by/4.0/ </small> | |
| SIGN | | | |
| ROADWORK DELINEATORS | | A3 | Standard Drawing No |
| | | Not to Scale | 1294 |
| | | | Date 11/2022 |
| A | B | C | D |