

The purpose of This Standard Drawing is to provide typical standard details. The fitness for purpose of these details for a specific project shall be designed and certified by an RPEQ. The details specific to the project location shall be shown on the project specific drawings.

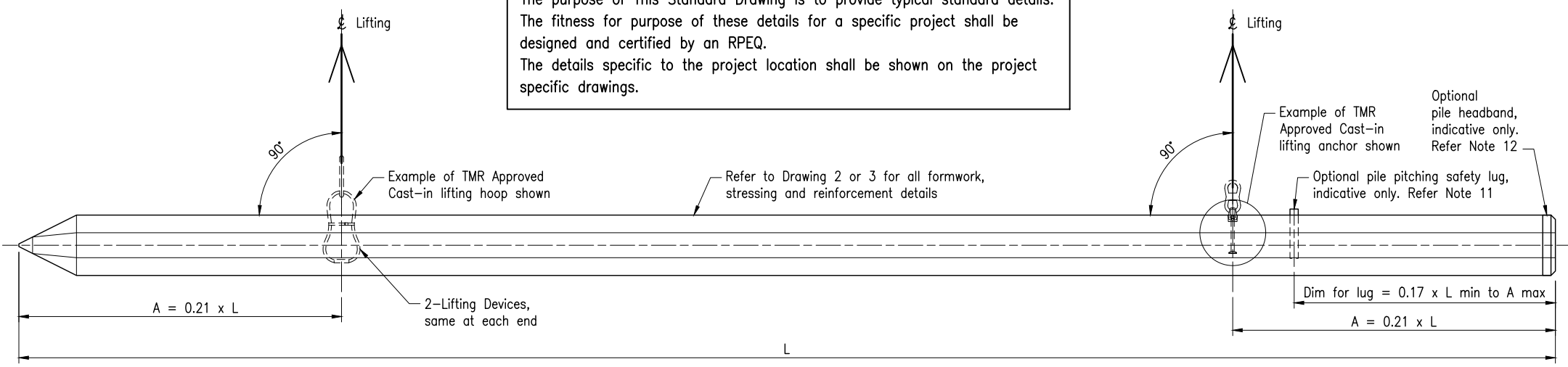

Pile Length L ≤ 28m PSC PILE

LIFTING DIAGRAM

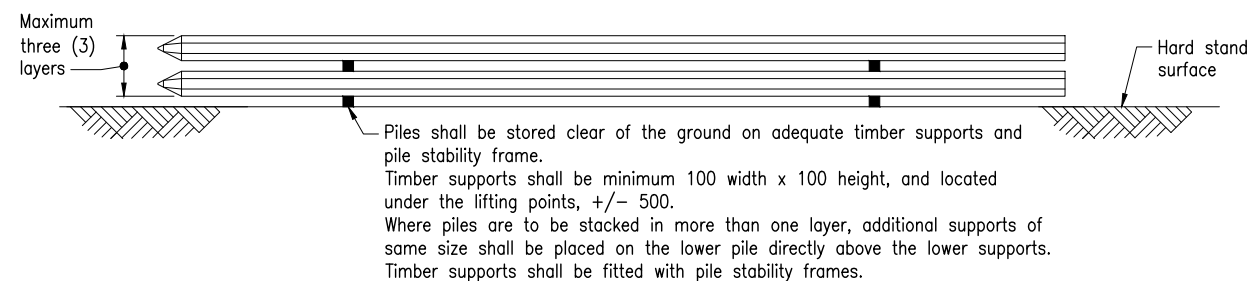

Pile Length L ≤ 28m PSC PILE

STORAGE AT CASTING YARD

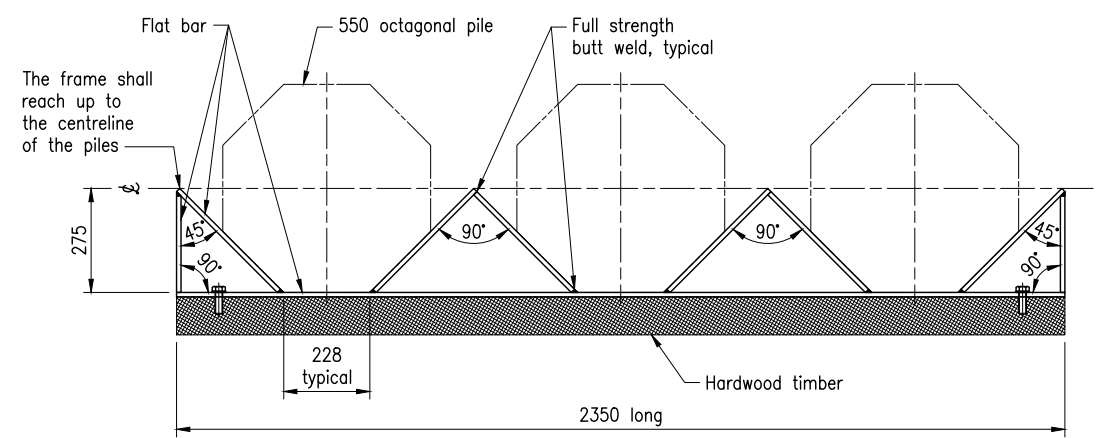

TYPICAL PILE STABILITY FRAME

Refer Note 7

INDEX – 550 OCTAGONAL PSC PILE – EARTHQUAKE CLASSIFICATION BEDC-1 and EXPOSURE CLASSIFICATION C1 and C2

DESCRIPTION	DRAWING REFERENCE
General Notes; Design Criteria, Notes and Details for Lifting	2022 Drawing 1 of 3
Details for PSC Pile with 12.7 Diameter Strands	2022 Drawing 2 of 3
Details for PSC Pile with 15.2 Diameter Strands	2022 Drawing 3 of 3

Note: The above index shall be included on the project drawings, amended to suit the requirements of the specific Project

DESIGN CRITERIA FOR 550 OCTAGONAL PSC PILES

- HELIX is valid for applications where the design is limited to less than or equal to half the axial ultimate capacity. For other design axial load, the fit for purpose requirements shall be included in the project drawings.
  - Maximum length of pile or individual pile segment shall be 28m.
- DESIGN CRITERIA FOR CAST-IN LIFTING ANCHORS AND HOOPS
- Details for cast-in lifting anchors and hoops shown in this standard drawing are indicative only. Lifting anchors and hoops shall be designed and RPEQ certified by project design engineer for project specific lifting arrangements for lifting at casting yard and site, as appropriate.
  - The lifting arrangements shown in this standard drawing are for lifting at casting yard only with gantry crane on steel rails or stationary hydraulic crane on outriggers. This is to meet the pile allowable concrete stress criteria in accordance with MRTS65 for pile length up to 28m. For all other lifting situations, including lifting at site, the pile shall be designed to meet the project specific lifting arrangements.
  - Site lifting with stationary hydraulic crane on outriggers, maximum dynamic factor of 1.5, is acceptable for pile length up to 28m. Lifting points shall be the same as shown. For higher dynamic factors, pile shall be checked and RPEQ certified by project design engineer to meet the allowable concrete stress criteria specified in MRTS65.
  - WORKING LOAD LIMIT (WLL): The WLL for each cast-in lifting anchor or hoop shall have an equivalent minimum Factor of Safety (FOS) = 4.0.
  - APPLIED LOADS (W<sub>A</sub>) calculated including an allowance for dynamic effects shall not exceed the Working Load Limit (WLL) of the cast-in lifting anchor or hoop.
  - All cast-in anchors and lifting hoops shall be designed for the appropriate Dynamic Lifting Factors (DLF) specified in MRTS73.
  - APPROVED CAST-IN ANCHORS AND HOOPS are published on the TMR Approved Product Index.
  - Suppliers of proprietary cast-in anchors and lifting hoops have various Factors of Safety (FoS) specified in their product capacity tables. These tables shall be converted to achieve a minimum FoS = 4.0, for Dynamic Lifting Factors outlined in MRTS73.
  - EMBEDMENT LENGTH of the cast-in anchor or lifting hoop shall be in accordance with manufacturer's specifications. Minimum cover to bottom of cast-in anchor or lifting hoop shall be 50mm.

CAST-IN LIFTING ANCHOR NOTES:

- RECESS: Anchor recess shall be hemispherical. Recesses shall be sized to allow proprietary lifting clutches to lock onto the lifting anchor, in accordance with manufacturer's specifications.
- RECESS FINISH: After lifting anchor is no longer required, fill with TMR approved epoxy resin grout or TMR approved cementitious grout. Epoxy resin grout or cementitious grout shall be suitable for high impact loads.

CAST-IN LIFTING HOOP NOTES:

- LIFTING shall be with minimum pin diameter as per manufacturer's specifications.
- HOOP FINISH: After lifting hoop is no longer required, cut-off flush with top of precast pile, apply three coats of approved surface tolerant epoxy compound to provide a minimum film thickness of 0.3mm dry or 0.6mm wet.

CAST-IN ANCHOR/HOOP LIFTING DETAILS

Pile Length	L = $\uparrow$
Cast-in Anchor/Hoop	Part No $\uparrow$
Working Load Limit (FOS = 4)	$\uparrow$
LIFTING ASSUMPTIONS, refer DESIGN CRITERIA	
Dynamic Load Factor	1.2 $\uparrow$
Lift Angle	Vertical $\uparrow$
Crane Type	Gantry $\uparrow$

$\uparrow$  The above details shall be included on the project drawings

GENERAL NOTES:

- PILES shall be manufactured to MRTS73.
- EARTHQUAKE classification BEDC-1.
- CONCRETE shall be in accordance with MRTS70. Concrete S50/20. Strength at transfer 35MPa minimum. Exposure classification C1 and C2. Minimum cover to reinforcement shall be 70 unless shown otherwise.
- REINFORCEMENT PATTERN: Headbar Types shall alternate and be placed adjacent to strands while maintaining as uniform a spacing as possible. Refer to HEADBAR SCHEDULE on DRAWING 2 or 3, as appropriate, for headbar details.
- REINFORCEMENT AND STRAND SUPPORT: Multiple spacers are permitted to be used in the following zones to maintain the correct strand pattern and headbar arrangement.
  - Zone with headbars: Spacers Type 1 shall be used to maintain the correct headbar formation during casting. Spacer Type 1 shall be located at 4000 maximum centres to form headbar cage. Minimum 2 off Spacer Type 1 shall be used.
  - Spacer Type 1 are permitted to be substituted with Type 2. Where substitutions are made headbars shall be tied to the inside of the Type 2 spacers. Strand and headbar bundle to be tied to main helix, and ties shall be at maximum 900 centres, typical.
  - Zone where there are no headbars: Spacers Type 2 shall be used to maintain the correct strand pattern formation during casting. Minimum 1 off Spacer Type 2 shall be used, located 4000 from the pile toe. Additional Spacers, where required, shall be placed at 4000 maximum centres.
- STRANDS shall be to MRTS73 and to AS/NZS 4672.1, and testing requirements to AS/NZS 4672.2.
  - Drawing 2: 7 wire ordinary-12.7-1870-Relax 2 pretensioning force at stressing = 138kN per strand.
  - Drawing 3: 7 wire ordinary-15.2-1750-Relax 2 pretensioning force at stressing = 187.5kN per strand; or, 7 wire ordinary-15.2-1830-Relax 2 pretensioning force at stressing = 196kN per strand.
- PILE STABILITY FRAME shown indicative only. Sizing of stability frame and its components shall be designed and RPEQ certified by the precaster's designer or contractor's designer. Frame width and number of piles per frame are to suit the storage layout of the precaster or contractor.
- REINFORCING STEEL shall be in accordance with Standard Drawings 1043 and 1044, MRTS71 and AS/NZS 4671.
  - Deformed bar Grade D500N. Round bar Grade R250N. Deformed wire Grade D500L. Round wire Grade R500L. All carbon reinforcing steel shall be ACRS certified.
- HELIX: N10 deformed bar and D500L7.6 deformed wire. Where lapping is required, the helix shall be spliced within its length with 1.5 turns, lapped and tied, and each ending with a 135° hook, in accordance with Standard Drawing 1044. Helix splices are permitted to be located within a Lifting Hoop.
- PILE CAST-IN LIFTING ANCHORS AND HOOPS shall be in accordance with the notes and details on this drawing.
  - Cast-in lifting anchors and hoops shall be hot dip galvanised to AS/NZS 1214.
- OPTIONAL SAFETY LUG may be cast into pile top surface for use with choker chain during pile pitching. Indicative details are shown in the drawings. Requirement and dimensions shall be confirmed subject to risk assessment by pile driving contractor. Lug shall be cut off and ground flush with surface of the pile during or after driving if directed by the Administrator. The lug and adjacent area of pile shall be coated with approved surface tolerant epoxy compound after grinding flush.
- OPTIONAL PILE HEADBAND may be used to minimise the risk of pile head spalling during pile driving. Indicative details are shown in the drawings. Requirement and details of pile headband shall be determined subject to assessment of risk and driving conditions by pile driving contractor.
- GREY IRON CASTING Grade ISO 185/JL/HBW195 to AS 1830.
- STEELWORK shall be fabricated to MRTS78.
  - Bolts Class 4.6 to AS 1111.1.
  - Stainless Steel material and fabrication shall be to MRTS78A.
- WELDING symbols shall be to AS 1101.3.
  - Welding of bar splices and tack welding for location purposes shall be to AS/NZS 1554.3.
  - Welding consumables shall be controlled hydrogen type G49X to AS/NZS ISO 14341-B or T49X to AS/NZS ISO 17632-B.
- DIMENSIONS are in millimetres unless noted otherwise.

ASSOCIATED DEPARTMENTAL DOCUMENT:

Design Criteria for Bridges and Other Structures

REFERENCED DEPARTMENTAL SPECIFICATIONS:

- MRTS65 Precast Prestressed Concrete Piles
- MRTS70 Concrete
- MRTS71 Reinforcing Steel
- MRTS73 Manufacture of Prestressed Concrete Members and Stressing Units
- MRTS78 Fabrication of Structural Steelwork
- MRTS78A Fabrication of Structural Stainless Steelwork

Department of Transport and Main Roads			
550 OCTAGONAL PSC PILES			
EARTHQUAKE CLASSIFICATION BEDC-1 EXPOSURE CLASSIFICATION C1 AND C2		A3	Standard Drawing No
DRAWING 1 OF 3		Not to Scale	2022 Date 3/2023

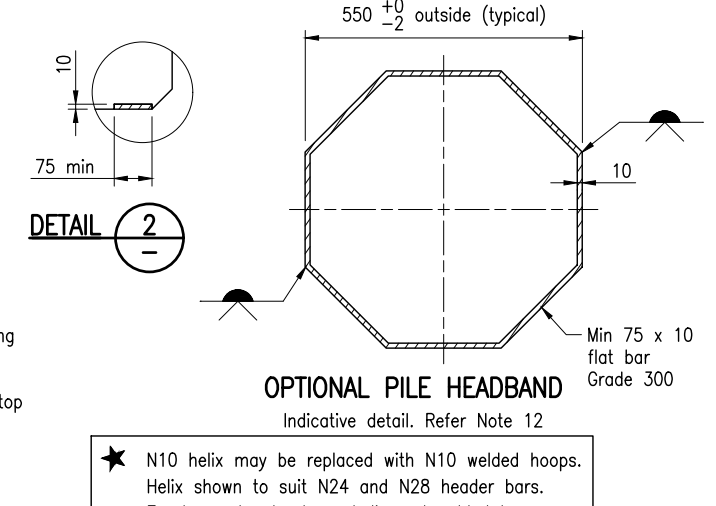
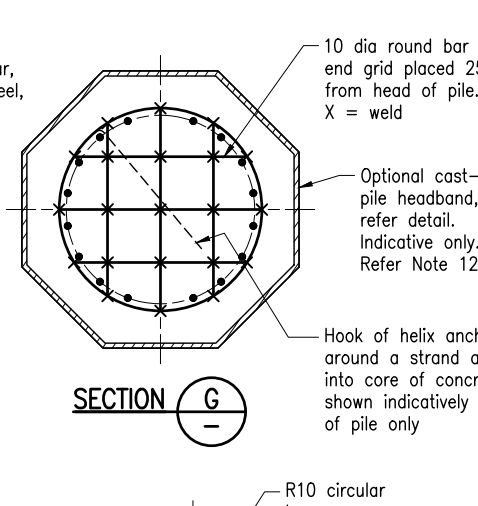
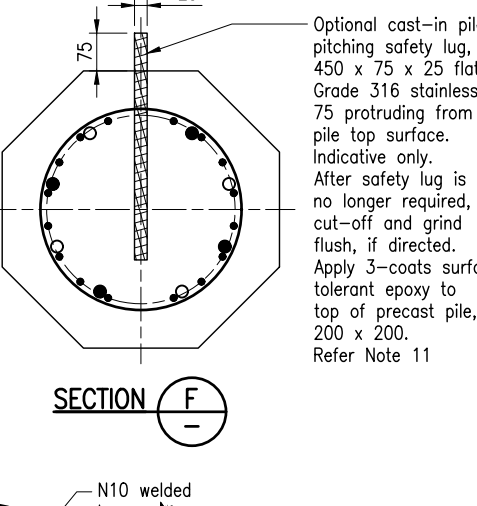
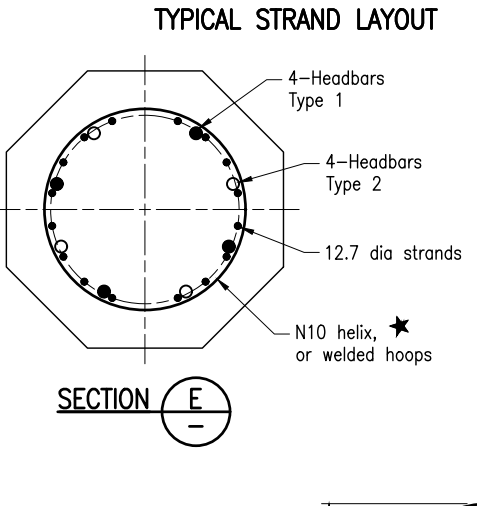
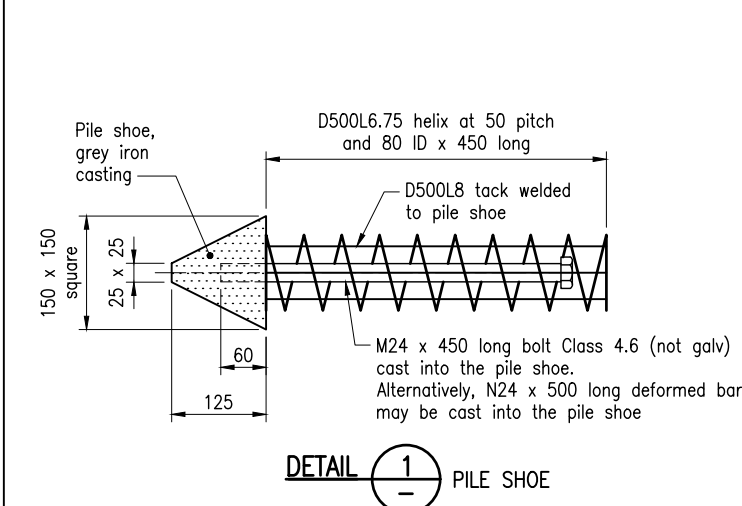
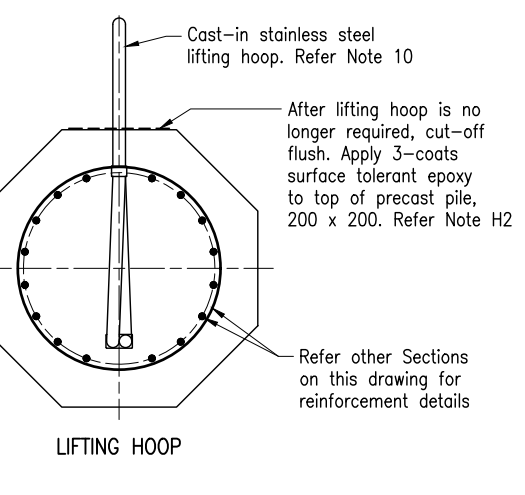
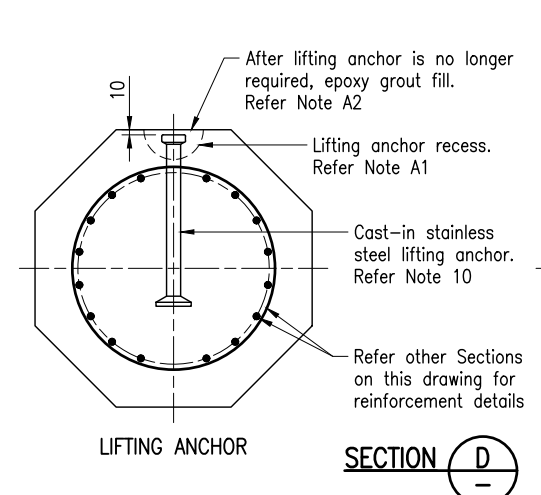
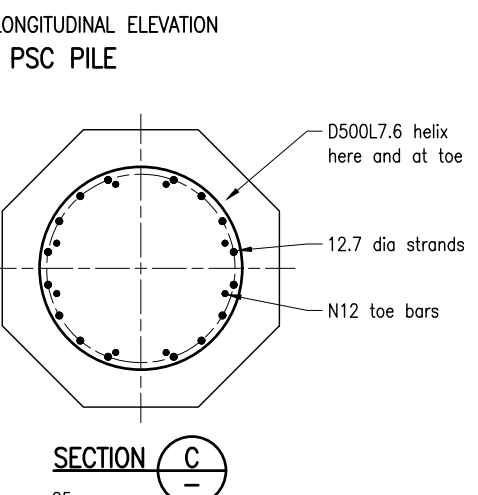
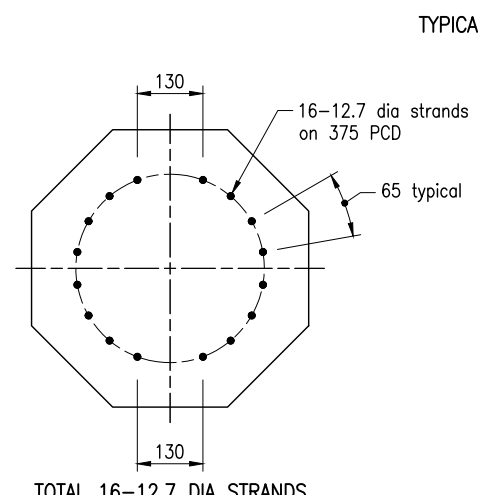
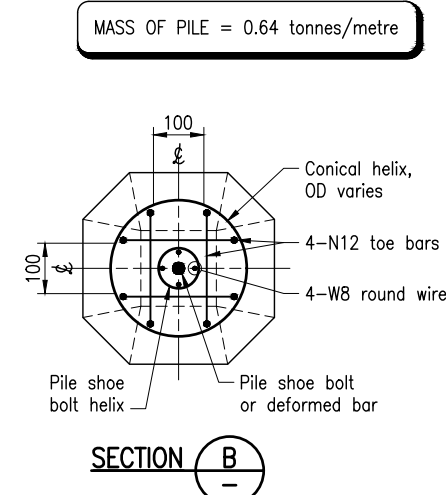
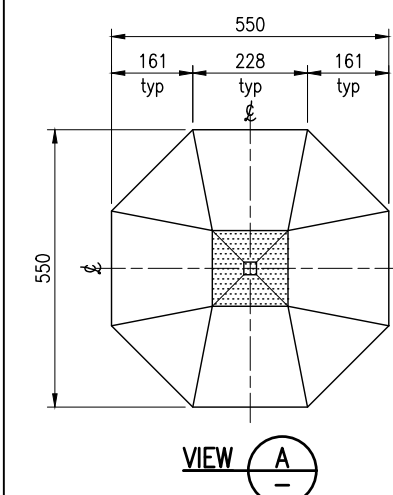
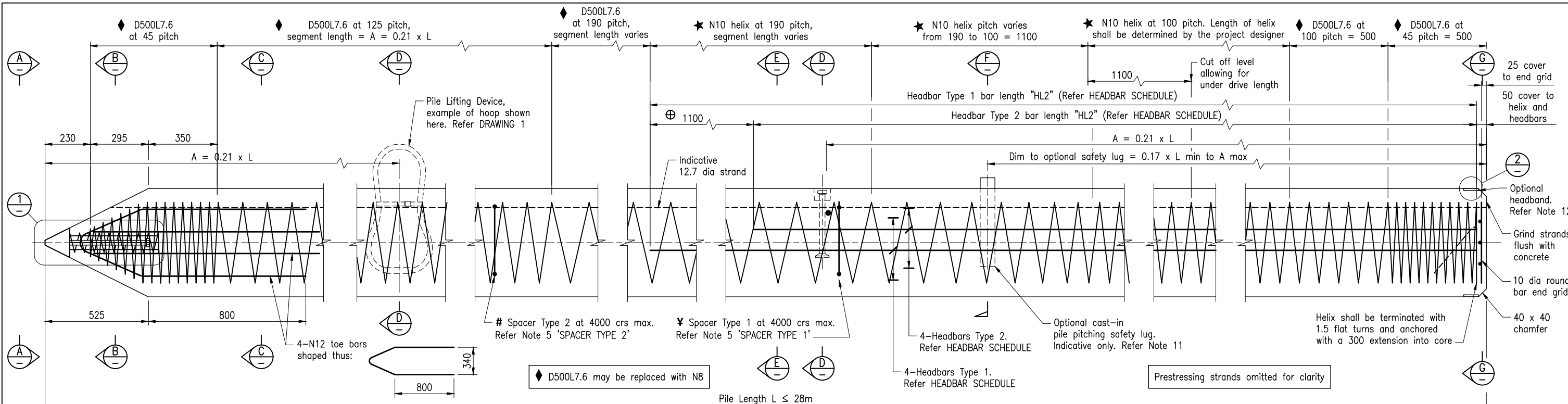

PILE LOCATION	PILE LENGTH (m)	MASS (t)	No OFF	TOTAL MASS (t)
xx	xx	xx.x	xx	xxx.x
xx	xx	xx.x	xx	xxx.x
xx	xx	xx.x	xx	xxx.x

xx denotes information to be included in the project drawings

Headbars					
Type 1			Type 2		
No OFF	Size	Length	No OFF	Size	Length
4	Nxx	HL1	4	Nxx	HL2

HEADBAR NOTES:  
Nxx denotes Bar size  
HL2 = HL1 - 1100  
The headbar length and size shall be included on the project drawings

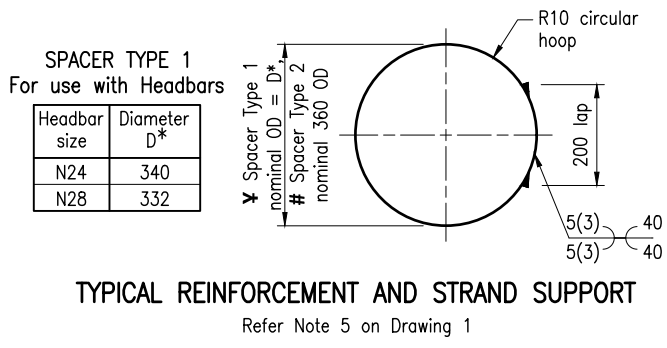
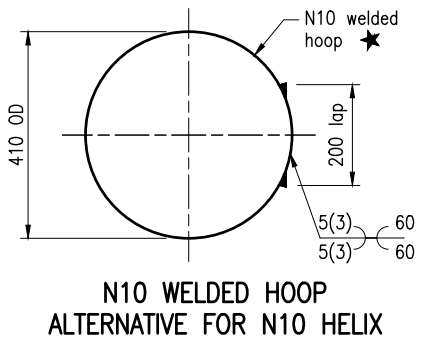

N10 helix may be replaced with N10 welded hoops. Helix shown to suit N24 and N28 header bars. For larger header bars, helix and welded hoops, details shall be in accordance with AS 5100.5

Department of Transport and Main Roads			
550 OCTAGONAL PSC PILES			
EARTHQUAKE CLASSIFICATION BEDC-1		Standard Drawing No <b>2022</b> Date 3/2023	A3 Not to Scale
EXPOSURE CLASSIFICATION C1 AND C2			
12.7 DIAMETER STRANDS		DRAWING 2 OF 3	

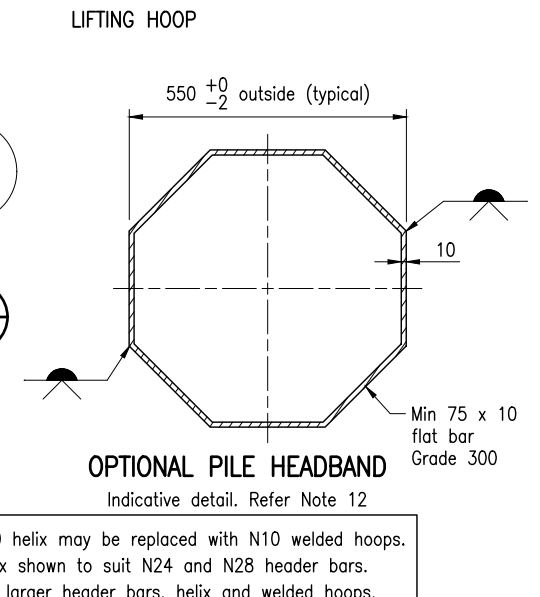
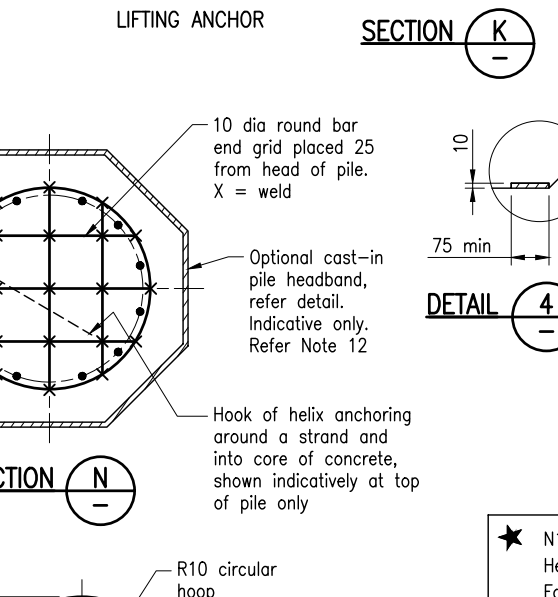
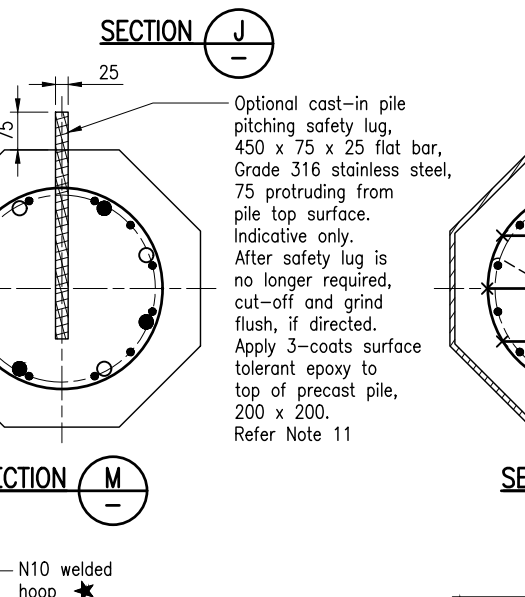
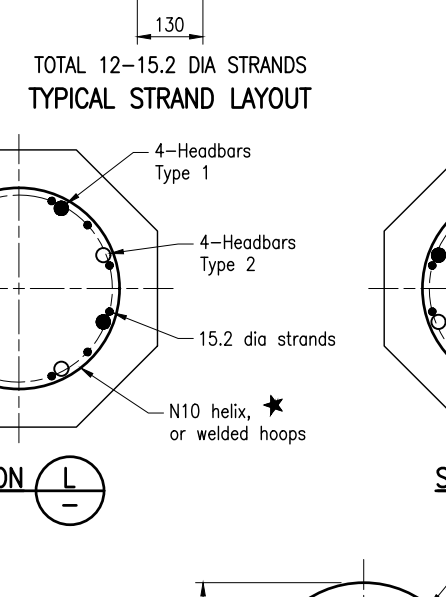
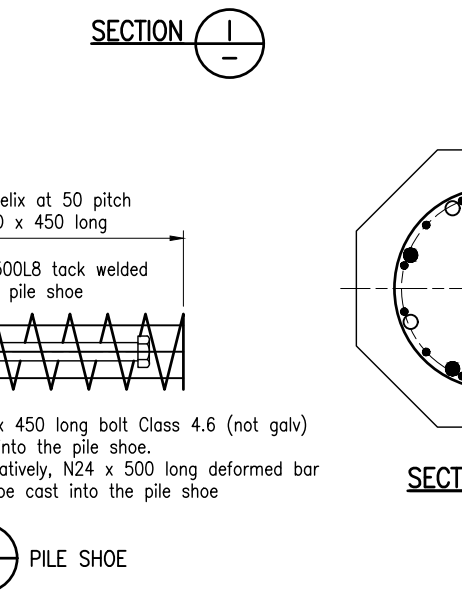
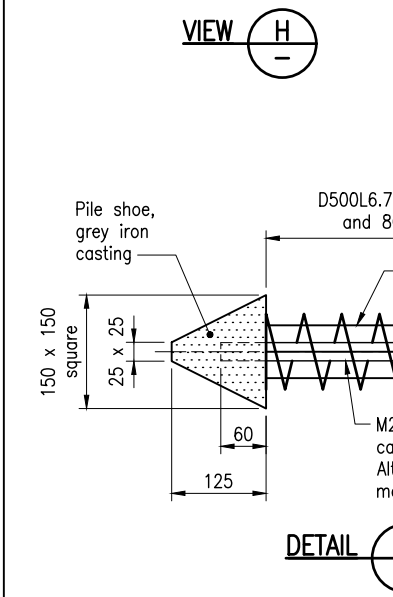
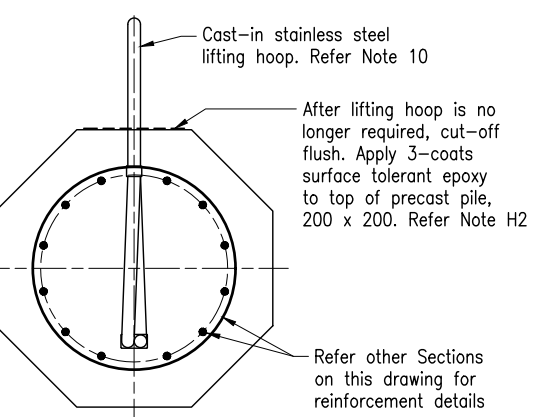
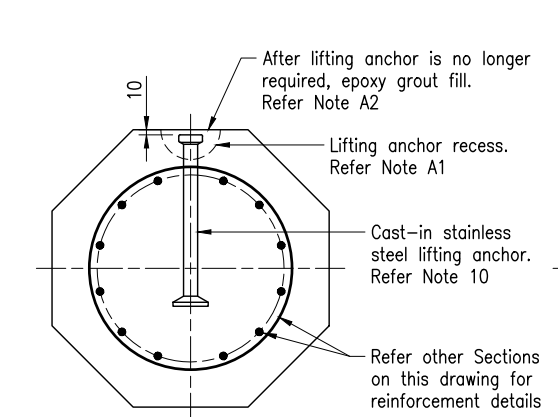
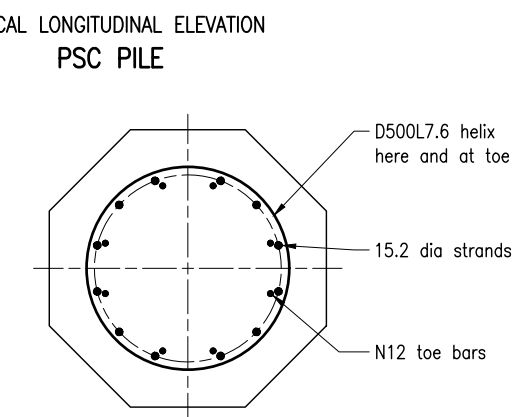
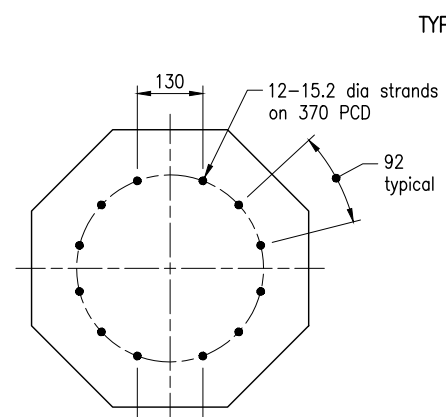
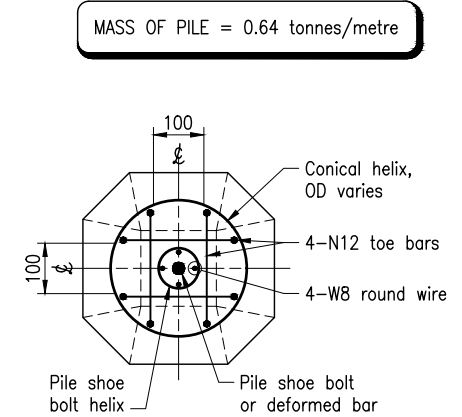
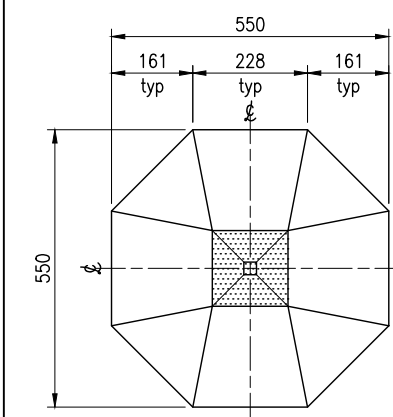
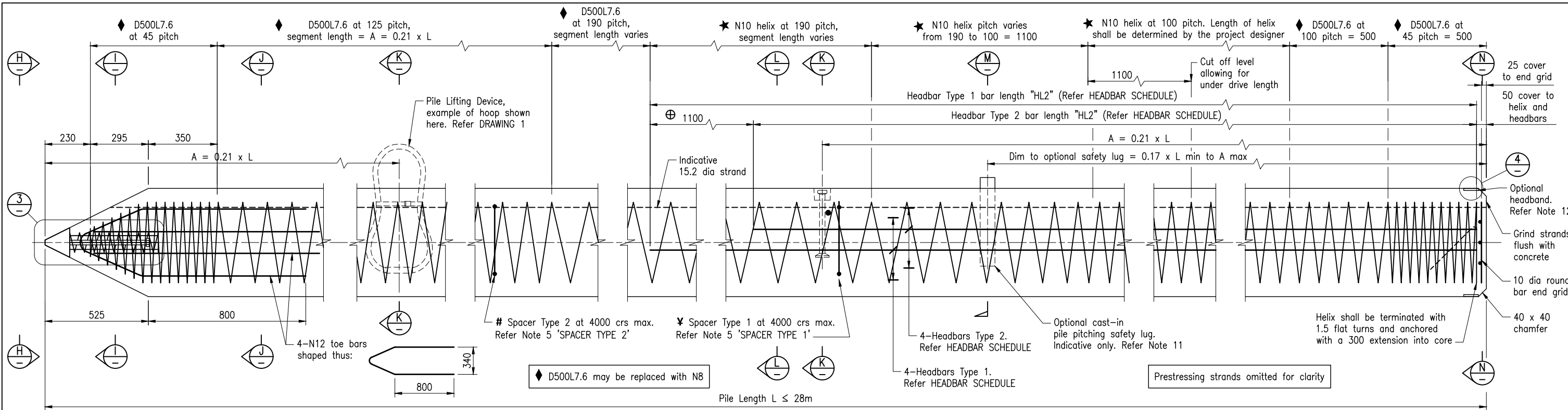

PILE LOCATION	PILE LENGTH (m)	MASS (t)	No OFF	TOTAL MASS (t)
xx	xx	xx.x	xx	xxx.x
xx	xx	xx.x	xx	xxx.x
xx	xx	xx.x	xx	xxx.x

xx denotes information to be included in the project drawings

Headbars					
Type 1			Type 2		
No OFF	Size	Length	No OFF	Size	Length
4	Nxx	HL1	4	Nxx	HL2

HEADBAR NOTES:  
Nxx denotes Bar size  
HL2 = HL1 - 1100  
The headbar length and size shall be included on the project drawings

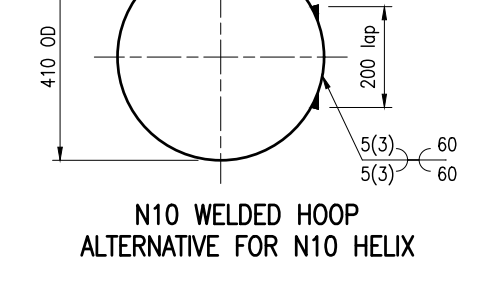

Headbar size	Diameter D*
N24	340
N28	332

Spacer Type 1 nominal OD = D\*  
# Spacer Type 2 nominal 354 OD

\* N10 helix may be replaced with N10 welded hoops. Helix shown to suit N24 and N28 header bars. For larger header bars, helix and welded hoops, details shall be in accordance with AS 5100.5

Department of Transport and Main Roads

550 OCTAGONAL PSC PILES

EARTHQUAKE CLASSIFICATION BEDC-1  
EXPOSURE CLASSIFICATION C1 AND C2  
15.2 DIAMETER STRANDS  
DRAWING 3 OF 3

Standard Drawing No  
**2022**  
Date 3/2023

Not to Scale

© The State of Queensland (Department of Transport and Main Roads) 2023  
http://creativecommons.org/licenses/by/4.0/