

Manual

Building Information Modelling (BIM) for Bridges Manual

November 2024

Copyright

© The State of Queensland (Department of Transport and Main Roads) 2024.

Licence



This work is licensed by the State of Queensland (Department of Transport and Main Roads) under a Creative Commons Attribution (CC BY) 4.0 International licence.

CC BY licence summary statement

In essence, you are free to copy, communicate and adapt this work, as long as you attribute the work to the State of Queensland (Department of Transport and Main Roads). To view a copy of this licence, visit: <https://creativecommons.org/licenses/by/4.0/>

Translating and interpreting assistance



The Queensland Government is committed to providing accessible services to Queenslanders from all cultural and linguistic backgrounds. If you have difficulty understanding this publication and need a translator, please call the Translating and Interpreting Service (TIS National) on 13 14 50 and ask them to telephone the Queensland Department of Transport and Main Roads on 13 74 68.

Disclaimer

While every care has been taken in preparing this publication, the State of Queensland accepts no responsibility for decisions or actions taken as a result of any data, information, statement or advice, expressed or implied, contained within. To the best of our knowledge, the content was correct at the time of publishing.

Feedback

Please send your feedback regarding this document to: tmr.techdocs@tmr.qld.gov.au

Contents

- 1 Introduction 1**
- 2 Definition of terms 2**
- 3 Referenced documents 3**
- 4 Bridge BIM model preparation 3**
 - 4.1 Bridge BIM model development and collaboration 3
 - 4.1.1 *Bridge BIM model software* 4
 - 4.2 Model geographical location 4
 - 4.3 Modelling units 4
- 5 Bridge BIM model objects..... 4**
 - 5.1 Bridge BIM model object identification and nomenclature 6
 - 5.1.1 *Bridge BIM model component codes* 6
 - 5.1.2 *Bridge BIM model object identification – full BIM object code* 8
 - 5.2 Bridge BIM model object naming convention 10
 - 5.2.1 *General and orientation of the bridge BIM model* 10
 - 5.2.2 *Substructure elements* 10
 - 5.2.3 *Superstructure* 16
 - 5.2.4 *Miscellaneous items* 22
 - 5.3 Bridge BIM model interface with the Bridge Information System 23
- 6 Bridge BIM model Level of Development for design development phases 24**
- 7 Bridge BIM model attributes 25**
 - 7.1 Transport and Main Road's bridge object property sets 25
- Appendix A – BIM Schedule example 27**

Tables

- Table 2 – Definition of terms..... 2
- Table 3 – Referenced documents 3
- Table 5 – Bridge BIM Model inclusions 5
- Table 5.1.1 – Bridge component code identifiers 6
- Table 5.1.2 – Bridge component group locations..... 9
- Table 5.3 – Bridge BIM model object .ifc assignment 23
- Table 6 – Bridge BIM model required Level of Development..... 24

Figures

- Figure 1 – Typical bridge BIM model for a girder bridge 1
- Figure 5(a) – Typical structure model of bridge objects for a girder bridge 4
- Figure 5(b) – Typical structure model of bridge objects for a deck unit bridge 5
- Figure 5.1.2(a) – Bridge object identification string – full BIM object code 8

Figure 5.1.2(b) – Full BIM object code example for a deck unit.....	9
Figure 5.1.2(c) – Full BIM object code example for a precast pile	9
Figure 5.2.2.1(a) – Object naming convention for PSC pile foundations	11
Figure 5.2.2.1(b) – Object naming convention for piled and pad foundations	11
Figure 5.2.2.2(a) – Object naming convention for abutments	12
Figure 5.2.2.2(b) – Object naming convention for abutments with multiple wingwalls.....	12
Figure 5.2.2.3(a) – Object naming convention for piers with headstock on PSC piles	13
Figure 5.2.2.3(b) – Object naming convention for piers with columns	13
Figure 5.2.2.4(a) – Object naming convention for bearings on piers	14
Figure 5.2.2.4(b) – Object naming convention for bearings on abutments	15
Figure 5.2.2.4(c) – Naming convention for bearing objects	15
Figure 5.2.3.1(a) – Naming convention for deck unit objects.....	17
Figure 5.2.3.1(b) – Naming convention for concrete girder (Super-T) objects.....	18
Figure 5.2.3.1(c) – Naming convention for concrete diaphragm objects	18
Figure 5.2.3.2(a) – Naming convention for deck objects of a transversely stressed bridge	19
Figure 5.2.3.2(b) – Naming convention for bridge deck objects.....	20
Figure 5.2.3.3 – Naming convention for bridge barrier objects	21
Figure 5.2.4 – Naming convention for expansion joint objects.....	22
Figure 7.1 – Example of attribute properties for a concrete girder.....	26

1 Introduction

The Department of Transport and Main Roads (the department) aims to realise the advantages which can be gained through the implementation of Digital Engineering processes during the design, delivery, and management of the asset. Digital Engineering implements Building Information Modelling (BIM) technologies and methodologies to create and manage a collaboration platform for all project stakeholders. The collaborative exchange of information between all project stakeholders enables data visualisation, improves planning and cost estimation, develops safety in design considerations, and provides the opportunity to present data throughout the lifecycle of the asset.

The purpose of the bridge BIM model is to provide an asset model of the structure, containing relevant information and data captured throughout the delivery stages, allowing the department to efficiently and effectively manage the asset. The preparation of the bridge BIM model will also assist the department in construction planning, design verification and coordination, throughout delivery of the project. The bridge BIM model aids in the collaboration and interface management between the road design, and other technical disciplines.

The bridge BIM model shall encompass the structural design of the bridge asset, in a complete three dimensional (3D) electronic model, that is progressively developed through the design stages, inclusive of project attributes, and suitable for construction coordination and field set out. Figure 1 provides an example of a typical bridge BIM model for a girder bridge.

This manual applies to the design development, construction, and presentation of As Constructed information of departmental bridges following the completion of the project.

This document must be read in conjunction with the Building Information Modelling (BIM) for Transport and Main Roads guideline and the Exchange Information Requirements (EIR) included in the contract documentation.

Figure 1 – Typical bridge BIM model for a girder bridge

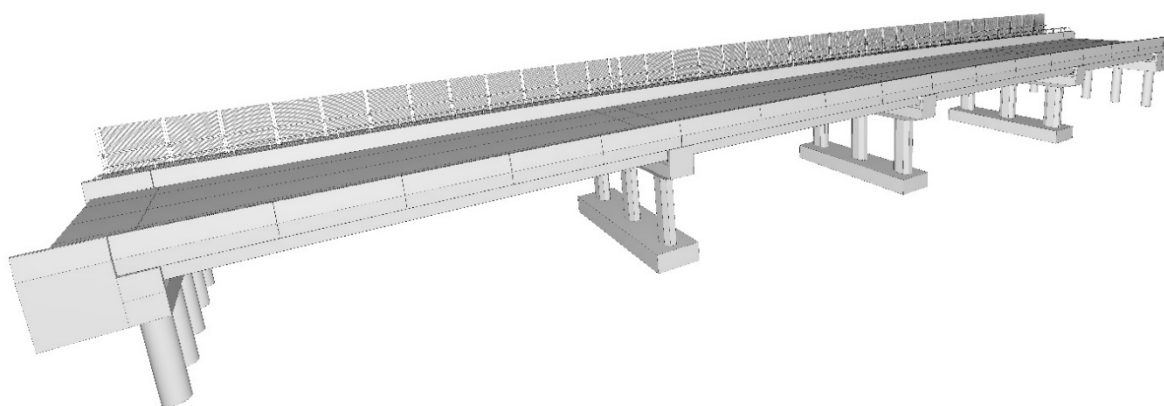

Technical Support

The content of this manual has been developed by the Transport and Main Roads BIM team. Technical support is available for application of the content of this manual at:

TMR_BIM_Team@tmr.qld.gov.au

2 Definition of terms

The following is a glossary of terms used in this manual.

Table 2 – Definition of terms

Term	Definition
Component	The physical, tangible object that is a part of the bridge, such as, precast girders, piles and headstocks.
3D model	Three dimensional digital model made of surfaces, solids and/or features representing project objects.
BIM	Building Information Model. 3D model with additional non spatial attributes about the objects and features.
GIS	Geographic Information System. A system that integrates hardware, software, and data for capturing, managing, analysing, and displaying all forms of geographically referenced information.
Closed surface	3D surface describing the complete envelope of a single object to allow volume calculation, clash detection etc.
Solid	3D representation of an object often equivalent to a closed surface with filling in plan and cross sections.
Object	The 3D closed surfaced solid, developed in the bridge BIM model that represents the bridge component. The object contains additional attributes capturing design, construction and asset management information.
Full BIM object code	The bridge objects in the bridge BIM model are to be named and identified using an object string that contains a number of parts which can be concatenated into shorter identification codes for displaying and presenting various information throughout the bridge's lifecycle.
Attribute	Data or information associated to an object, such as its name, unique identifier or material.
.ifc	An open source, international standard (ISO 16739-1), which is vendor-neutral, and usable across a wide range of hardware devices and software platforms.
BAMS	Bridge Asset Management System. The department's system to effectively and efficiently manage bridge assets across Queensland.
BIS	Bridge Information System. The department's established system of integrated and accessible information for bridge inventory, condition, load capacity, and inspection and works history.
SIM	<i>Structures Inspection Manual</i>

3 Referenced documents

Table 3 lists documents referenced in this manual.

Table 3 – Referenced documents

Reference	Title
Design Criteria	<i>Design Criteria for Bridges and Other Structures</i>
Drafting and Design Presentation Standards Manual	<i>Drafting and Design Presentation Standards Manual, Volume 3, Structural Drafting Standards</i>
Structures Inspection Manual	<i>Structures Inspection Manual</i>
TMR object attributes for bridges	<i>Transport and Main Roads object attributes for bridges</i>
MRTS50	<i>Specific Quality System Requirements</i>
MRTS56	<i>Construction Surveying</i>
TMR BIM Guideline	<i>Building Information Modelling (BIM) for Transport and Main Roads guideline</i>
EIR	<i>Transport and Main Roads Building Information Modelling (BIM) Exchange Information Requirements</i>

4 Bridge BIM model preparation

The major deliverable from the design consultant is a complete component based 3D electronic model which adequately outlines the final design geometry and structural objects of the bridge. The design consultant shall progressively develop the bridge BIM model throughout the design development of the bridge. The bridge BIM model shall be submitted for the department's review with the corresponding design drawings at each of the design development phases outlined in the *Design Criteria for Bridges and Other Structures*, and as requested by the department throughout the design period.

4.1 Bridge BIM model development and collaboration

The bridge BIM model shall be used for collaboration and interfacing with the road design and other technical disciplines. In all design scenarios, whether the design consultant is responsible for the bridge design only, or responsible for the bridge design and multiple other technical disciplines, the design consultant shall maintain the bridge BIM model that represents the current design status of the bridge. Where the bridge BIM model includes design details from other technical disciplines, for example the road design, ITS and drainage, these details shall be included in separate discipline models.

Where multiple bridges are included in a contract, the design consultant shall develop and maintain a separate bridge BIM model for each bridge asset. Each separate bridge BIM model shall be submitted to the department at each of the design development phases outlined in the *Design Criteria for Bridges and Other Structures*. In addition, the design consultant shall develop a master model federating each of the bridge BIM models, in real world coordinates, throughout the design process.

All model design levels must refer to the Australian Heights Datum (AHD), and all plan coordinates must refer to the Map Grid of Australia (MGA).

4.1.1 Bridge BIM model software

The department does not dictate the structural design software to be used to develop the bridge BIM model, thereby allowing flexibility in efficiencies with already established work practices. For efficiencies in work effort, and where capability exists within the consultant's organisation, it is preferred that when submitting the bridge BIM model, the design consultant shall provide the model in the following formats:

- Industry Foundation Class files (.ifc)
- Navisworks File (NWD)
- Navisworks Cache File (NWC), and
- Native files in the software package used to develop the model.

The design consultant may choose to use alternative software to achieve efficiencies in the design process, automation, and utilise office based developments. The design consultant shall provide all native modelling files used to produce the design model to the department.

4.2 Model geographical location

Geographic location is to conform to the requirements for Survey Datum as outlined in the *TMR Surveying Standards Part 1 – General Information*.

4.3 Modelling units

The native bridge BIM model shall be developed so that dimensions are presented in millimetres.

5 Bridge BIM model objects

The bridge BIM model shall contain all objects necessary to outline the complete structural design (refer to Figure 5(a) and Figure 5(b)), interface with other technical disciplines, such as road design, and enable the construction of the project works. The minimum objects to be included in the bridge BIM model, are outlined in Table 5.

The department will integrate the bridge BIM model with GIS project systems, cost estimating, scheduling, component tracking, and asset management systems. To achieve this integration with a wide range of departmental systems, the objects within the bridge BIM model shall be developed and modelled as closed surfaces and solids. The objects shall be uniquely identified (Section 5.1) and organised into a logical system representing the structural bridge components.

Figure 5(a) – Typical structure model of bridge objects for a girder bridge

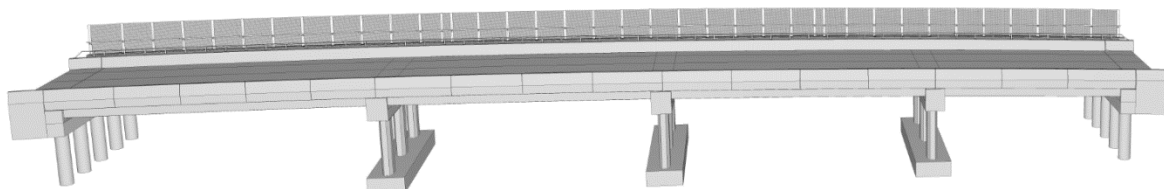

Figure 5(b) – Typical structure model of bridge objects for a deck unit bridge

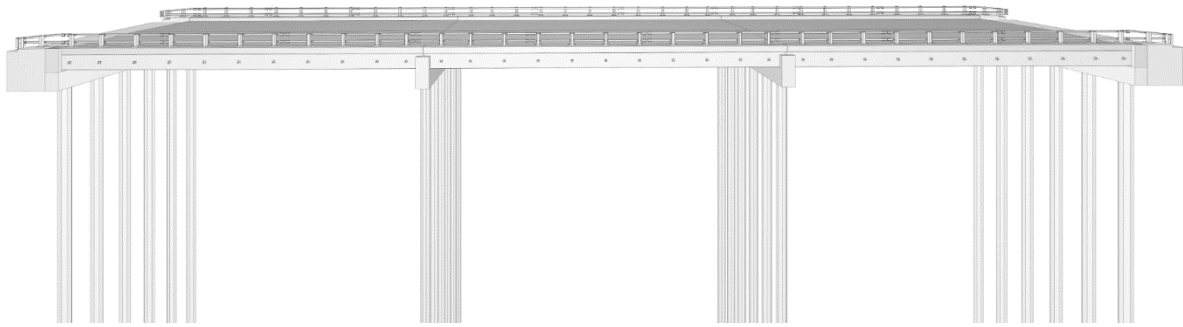

Table 5 – Bridge BIM Model inclusions

Design Component	Bridge Component
Superstructure	<ul style="list-style-type: none"> • Deck surface • Deck units and transverse bars / girders (with assumed hog – to be confirmed) • Diaphragms • Drainage penetrations • Kerbs • Traffic barriers (with precast / fabrication unit breakdown and cast in place elements such as hold down bolts) • Parapets and fascia panels • Deck joints and cover plates (to indicate location on bridge deck. No detail required for finger joints etc.) • Deck wearing surface • Balustrades and safety rails (including fabrication unit breakdown and cast in place elements such as hold down bolts) • Safety screens (including fabrication unit breakdown and cast-in place elements such as hold down bolts) • Public utility plant (PUP)
Substructure	<ul style="list-style-type: none"> • Abutments (including relieving slabs) • Abutment protection defining and detailing the toe levels • Piles and pile caps • Headstocks • Wing walls • Columns and pier walls • Taper plates, mortar pads, pedestals and bearings • Lateral restraint blocks • Wingwalls • Reinforced soil structure (RSS) walls
Approach	<ul style="list-style-type: none"> • For each approach 25 m minimum of road alignment and embankment / cutting approaching the bridge abutment
Overpass bridge	<ul style="list-style-type: none"> • Minimum 40 m of road alignment of the road that is positioned under the bridge centred about the centreline of the overpass bridge

5.1 Bridge BIM model object identification and nomenclature

In order to integrate the bridge BIM model into the department's network of bridge BIM models and future GIS network of bridges, unique identifiers shall be applied to each of the objects. These objects collectively form the bridge BIM model Schedule of Objects (SoO), representing the components of the bridge structure. An example of this bridge BIM model SoO and the identification of each object is shown in Appendix A: *BIM Schedule example*.

5.1.1 Bridge BIM model component codes

The bridge components are organised into groups representing their general location on the bridge. The BIM component code includes the single letter group code and the dual letter component code. Table 5.1.1 outlines the BIM code identifiers for each bridge component.

Table 5.1.1 – Bridge component code identifiers

Group	Group code	Component	Component code	BIM Component code
Abutments	A	Headstocks	HS	A-HS
		Wing walls	WW	A-WW
		Abutment protections	AP	A-AP
		Relieving slabs	RS	A-RS
		Retaining walls (includes RSS walls)	RW	A-RW
		Blade walls	BW	A-BW
		Deflection walls	DW	A-DW
Piers	P	Headstocks	HS	P-HS
		Pier columns	CO	P-CO
		Blade walls	BW	P-BW
		Deflection walls	DW	P-DW
Foundations	F	Precast piles	PP	F-PP
		Cast in place piles	CP	F-CP
		Pile caps	PC	F-PC
		Driven tubular steel piles	SP	F-SP
		Pad (spread) footings	PF	F-PF
Bridge Traffic Barriers	T	Steel post and rail types	TR	T-TR
		Concrete parapet types	TC	T-TC
		Pedestrian / shared balustrades	BA	T-BA
		Safety rails	SR	T-SR
		Safety screens / Anti throw screens	SS	T-SS
		Noise barriers	NB	T-NB
		Guard rails	GR	T-GR

Group	Group code	Component	Component code	BIM Component code
Bridge bearings	B	Elastomeric bearings	BE	B-BE
		Pot bearings	BP	B-BP
		Spherical bearings	BS	B-BS
		Thrust bearings	BT	B-BT
		Rocker bearings	BR	B-BR
		Bearing pedestals	PE	B-PE
		Restraint angles	RA	B-RA
		Restraint blocks	RB	B-RB
		Restraint plates	RP	B-RP
		Mortar pads	MP	B-MP
Decks	D	Cast insitu kerbs	KE	D-KE
		Cast insitu decks	DK	D-DK
		Holding down bolts	HB	D-HB
		Anchorage	AN	D-AN
		Deck wearing surfaces	AC	D-AC
		Shared paths / footways	FW	D-FW
		Fascia panels	FP	D-FP
		Cross girders	XG	D-XG
Girders	G	Deck units	DU	G-DU
		Transverse bars	TB	G-TB
		Concrete girders	CG	G-CG
		Winged planks	WP	G-WP
		Fibre composite girders	FC	G-FC
		Steel girders	SG	G-SG
		Timber girders	TG	G-TG
		Diaphragms	DI	G-DI
Miscellaneous	M	Drainage scuppers	DS	M-DS
		Drainage pipes	DP	M-DP
		PUP communication conduits	CC	M-CC
		PUP electrical conduits	CE	M-CE
		Joints	JT	M-JT
		Expansion joints	EJ	M-EJ

Group	Group code	Component	Component code	BIM Component code
		Cover plates	CV	M-CV
		Lighting brackets	LB	M-LB
		Anchorage	AN	M-AN

5.1.2 Bridge BIM model object identification – full BIM object code

The bridge objects in the bridge BIM model are to be named and identified using the object string outlined in Figure 5.1.2(a). This is defined as the full BIM object code. The full BIM object code contains a number of parts which can be concatenated into shorter identification codes for displaying and presenting various information throughout the bridge's lifecycle.

Figure 5.1.2(a) – Bridge object identification string – full BIM object code

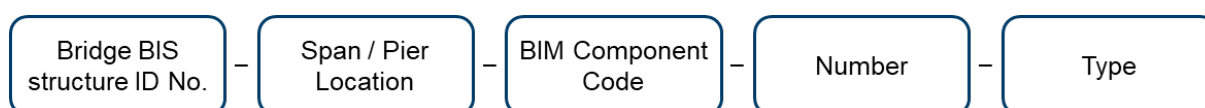

Notes and string part definitions

1. The full BIM object code shall be a continuous string with no spaces.
2. The full BIM object code parts shall be combined using hyphens (-) to form the continuous string.
3. The BIS structure identification number shall be provided by Transport and Main Roads. The department acknowledges the BIS structure identification number may not be available due to the following:
 - a) the development of the bridge BIM model may be for concept planning, business case development, or preliminary design stages
 - b) the BIS structure identification number may be provided after the bridge design has well progressed, and
 - c) in large projects where, in instances, the BIS structure identification number is generated upon the completion of the project, and bridges are identified with internal project numbers such as, BR01, BR02, etc.

In these scenarios, a generic place holder is acceptable to be used for the bridge BIS structure identification number part of the object identification string, such as, BR01, BR02, etc. It is the responsibility of the design consultant developing the bridge BIM model to ensure the place holder can be easily and seamlessly amended to the BIS structure identification number.

4. Span / pier location: the objects are located at either an abutment / pier or a span. The component groups identified by piers / abutments and spans are outlined in Table 5.1.2.

Table 5.1.2 – Bridge component group locations

Object Location	Bridge Component Groups
Pier and Abutment	<ul style="list-style-type: none"> • Abutment • Relieving slabs • Pier • Foundation • Bridge bearings • Miscellaneous (joints and expansion joints)
Span	<ul style="list-style-type: none"> • Girders • Bridge traffic barriers • Deck

5. BIM component code: the BIM code identifier for each bridge component, outlined in Section 5.1.1.
6. Number: the object number in the location sequence, for example, 001.
7. Type: used to distinguish different varieties of a bridge component. For example, internal and edge deck units, different bridge bearings, different precast fascia panels, and various fabricated steel components. The type is an alphabetical letter.

Figure 5.1.2(b) and Figure 5.1.2(c), provide examples of the full BIM object code for a deck unit and a precast pile respectively.

Figure 5.1.2(b) – Full BIM object code example for a deck unit

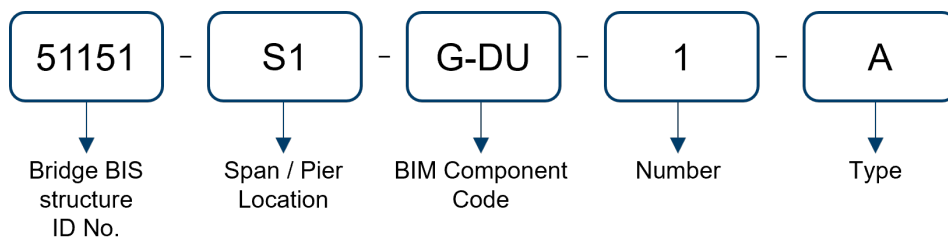
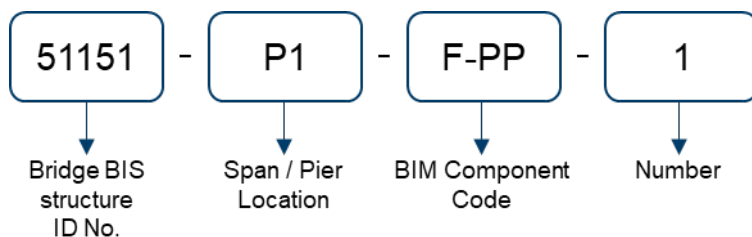

Figure 5.1.2(c) – Full BIM object code example for a precast pile



5.2 Bridge BIM model object naming convention

5.2.1 General and orientation of the bridge BIM model

Bridge BIM model objects are generally identified and named following the methodologies outlined in the department's *Drafting and Design Presentation Standards* Manual. The bridge BIM model shall be orientated such that the first abutment substructure along the gazettal is identified as ABUTMENT A, and the other abutment is identified as ABUTMENT B. Pier and span numbers shall be numbered sequentially along the gazettal.

The designation of substructure and superstructure objects generally adopts the object locations outlined in Table 5.1.2. Miscellaneous items are an exception to this general designation.

5.2.2 Substructure elements

5.2.2.1 Foundation

Figure 5.2.2.1(a) and Figure 5.2.2.1(b) show the naming convention for foundation objects in the bridge BIM model. The naming convention adopts the following methodology:

- Piled foundations (including precast piles and cast in place piles) are numbered sequentially left-to-right along a section looking 'up chainage' (increasing chainage).
- Where a pier contains multiple lines of piled foundations, the piles of the first line (lowermost chainage where the centreline of the pile line intersects the gazettal) shall be numbered sequentially left-to-right along a section looking "up chainage". Succeeding lines of piled foundations for the pier shall be numbered in a similar manner, with the number sequence continued from the previous line.
- It is common for abutments to contain piles under the wing walls. In these cases, the piled foundations for ABUTMENT B shall be named in a similar manner to a pier with multiple lines of piled foundations. However, for ABUTMENT A, the piled foundations shall be numbered right-to-left looking 'down chainage' (decreasing chainage).
- Pile caps and pad (spread) footings are identified and numbered at their respective pier or abutment location. In cases where there are multiple pile caps or pad (spread footings) at a single pier or abutment location, the pile caps or pad (spread) footings shall be numbered sequentially left-to-right along a section looking 'up chainage'.

Figure 5.2.2.1(a) – Object naming convention for PSC pile foundations

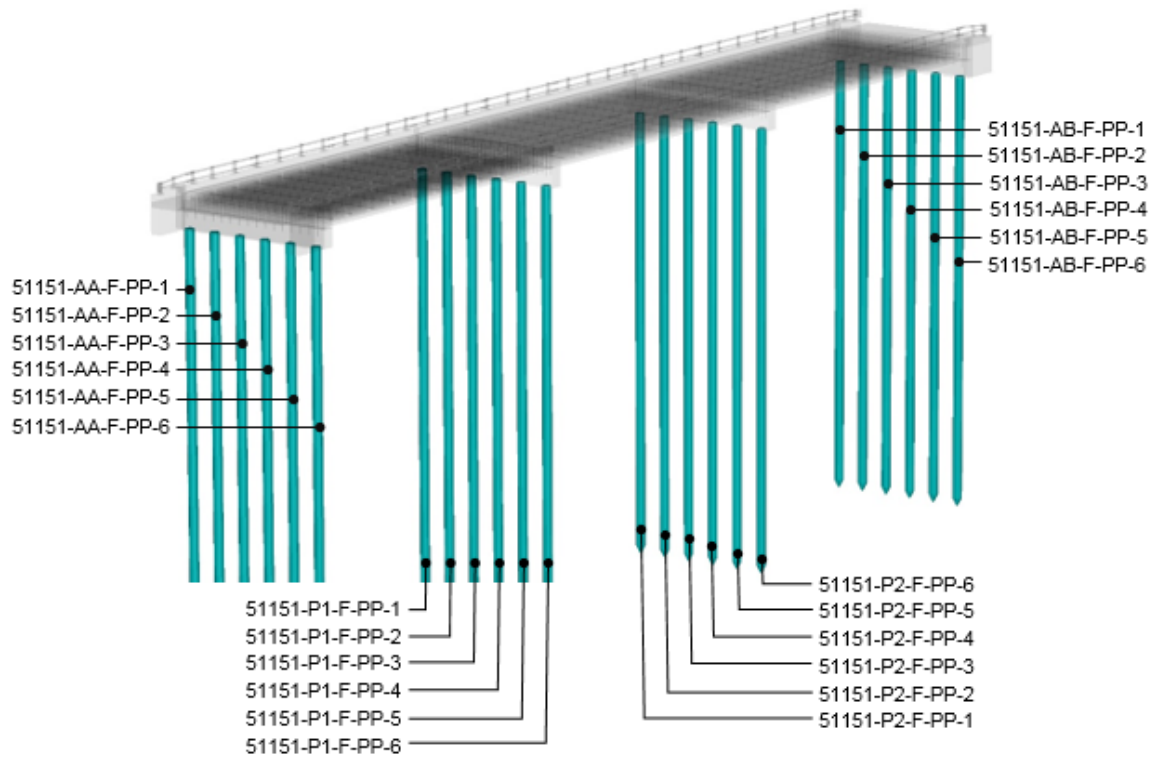
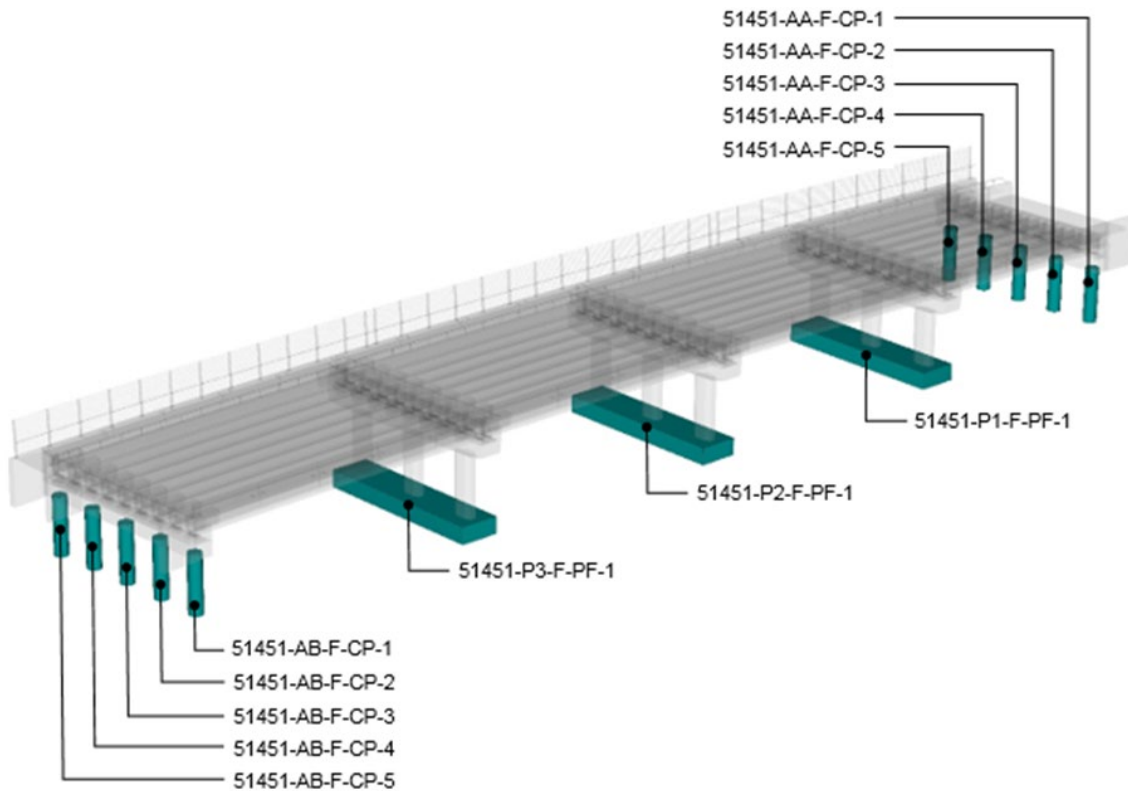

Figure 5.2.2.1(b) – Object naming convention for piled and pad foundations



5.2.2.2 Abutment

Figure 5.2.2.2(a) and Figure 5.2.2.2(b) show the naming convention for abutment objects in the bridge BIM model. The naming convention adopts the following methodology:

- Headstocks, relieving slabs and abutment protection are identified and numbered at the respective location, and
- Abutment wing walls are numbered sequentially left-to-right along a section looking 'up chainage' (increasing chainage). This results in the wing walls of each abutment numbered the same on the same side of the bridge.

Figure 5.2.2.2(a) – Object naming convention for abutments

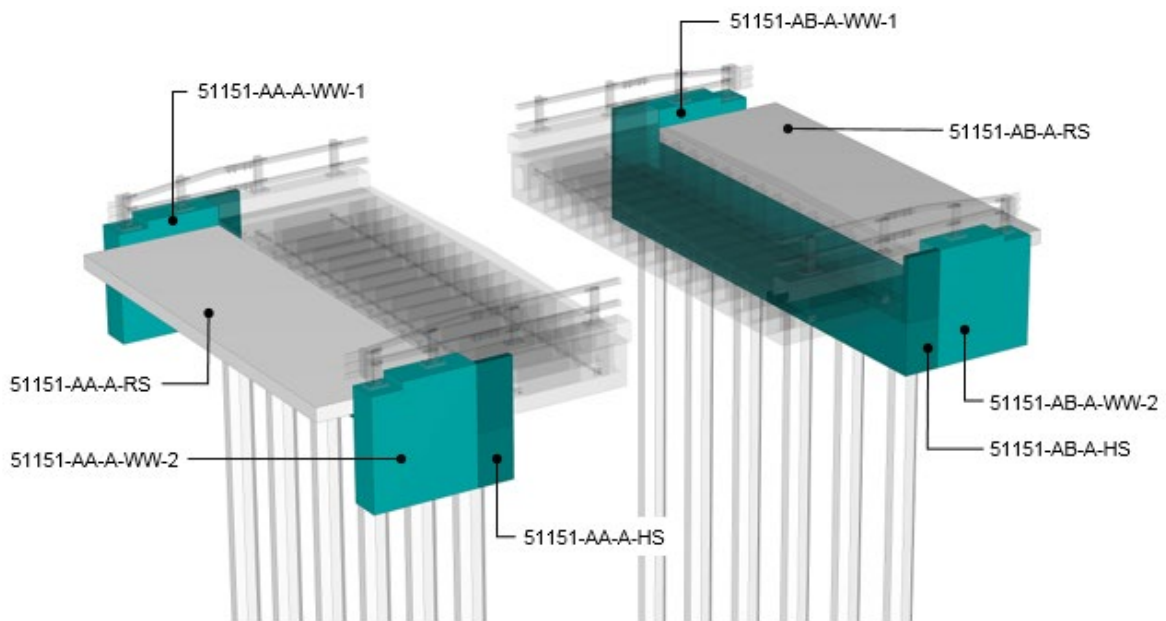
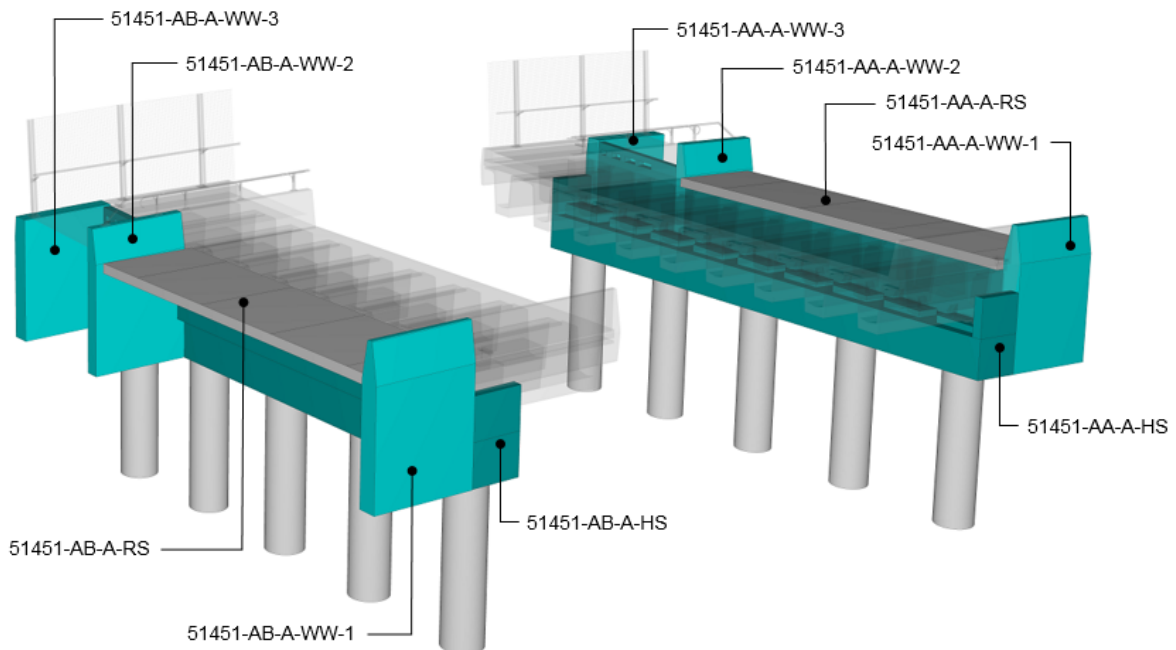

Figure 5.2.2.2(b) – Object naming convention for abutments with multiple wingwalls



5.2.2.3 Pier

Figure 5.2.2.3(a) and Figure 5.2.2.3(b) show the naming convention for pier objects in the bridge BIM model. The naming convention adopts the following methodology:

- Headstocks are identified and numbered at the respective location. Headstock side walls (also referred to as keeper walls) do not need to be separated from the main headstock object, and
- Pier columns and blade walls are numbered sequentially left-to-right along a section looking 'up chainage' (increasing chainage).

Figure 5.2.2.3(a) – Object naming convention for piers with headstock on PSC piles

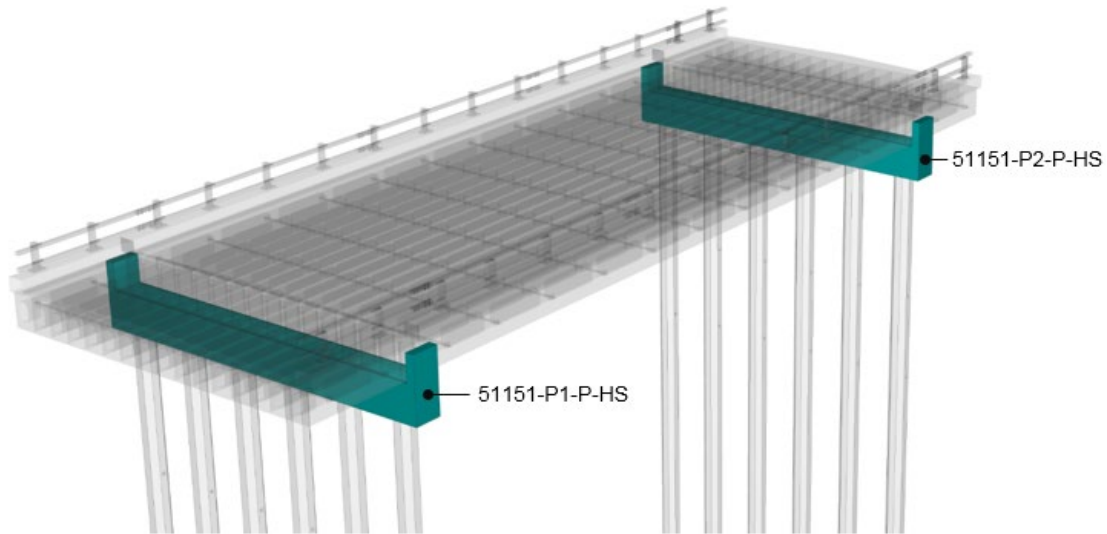
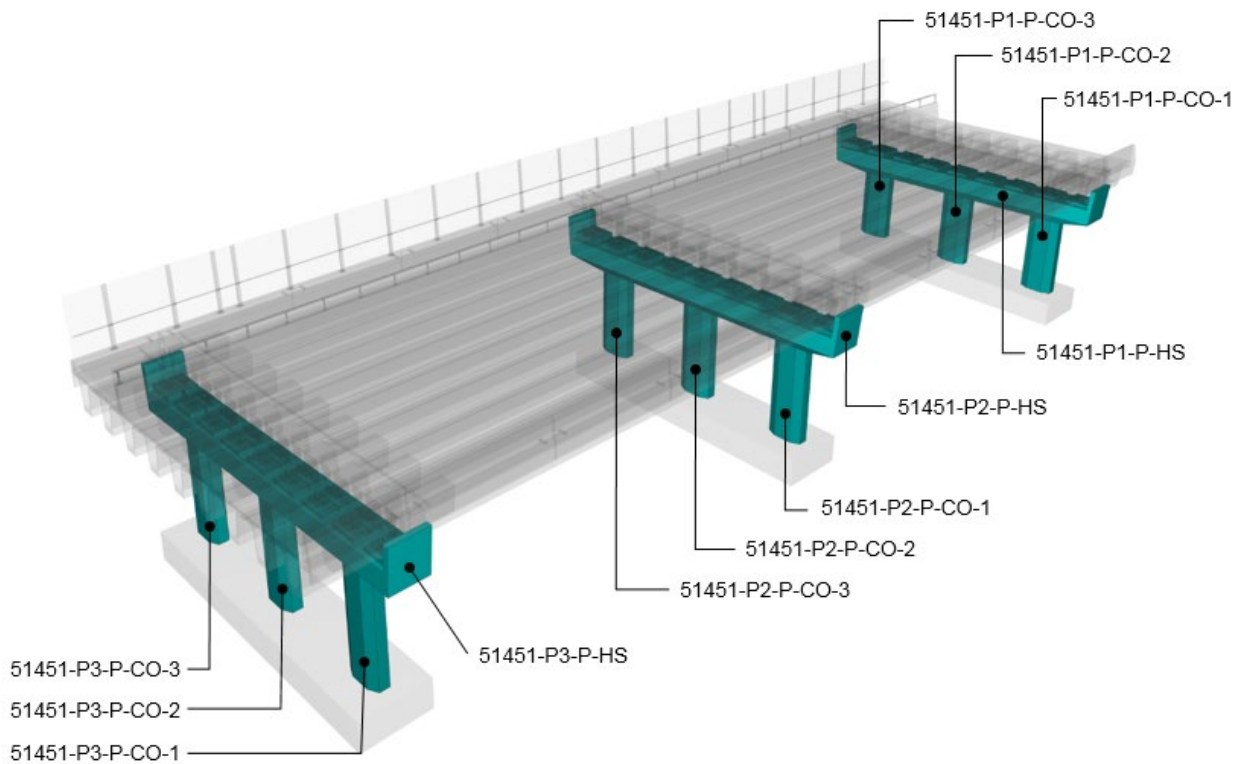

Figure 5.2.2.3(b) – Object naming convention for piers with columns



5.2.2.4 Bridge bearings

Figure 5.2.2.4(a), Figure 5.2.2.4(b) and Figure 5.2.2.4(c) show the naming convention for the group of bridge bearing objects in the bridge BIM model. The naming convention adopts the following methodology:

- The group of bridge bearing objects are located at the respective abutment or pier.
- Bearings (elastomeric, pot, spherical, thrust, and rocker), pedestals and restraint angles at abutments and piers are numbered sequentially left-to-right along a section looking 'up chainage' (increasing chainage).
- Where there are two lines of bearings on a pier, the first line (lowermost chainage where the centreline of the line intersects the gazettal) of bearings, pedestals and restraint angles shall be numbered sequentially left-to-right along a section looking 'up chainage'. The second line shall be numbered in a similar manner, with the number sequence continued from the previous line.
- Restraint angles are numbered as a group attached to the girder at the bearing location, i.e. there are two restraint angles to the group. The different types of restraint angles to be fabricated are identified using the 'type' part of the full BIM object code outlined in Section 5.1.2.
- Restraint blocks are identified and numbered at the respective abutment or pier location.
- Mortar pads can either be numbered as a complete object over the headstock supporting two spans of girders, or can be separated into two objects representing the mortar pad supporting each span of girders. This shall be adopted for stepped headstocks supporting girders with different depths.

Figure 5.2.2.4(a) – Object naming convention for bearings on piers

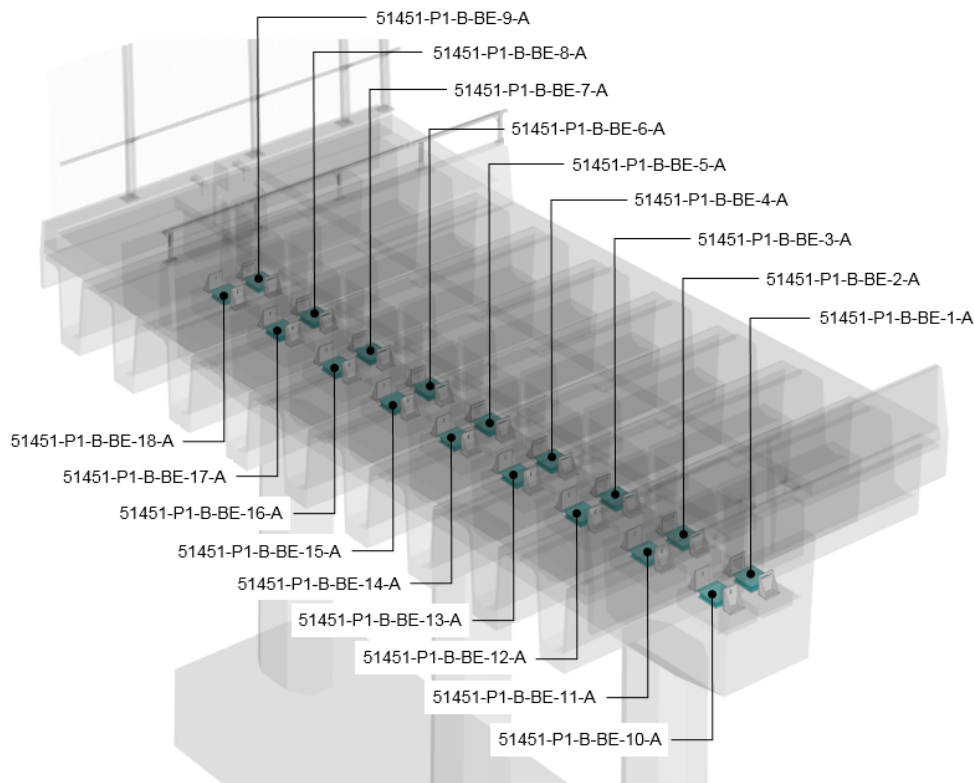

Figure 5.2.2.4(b) – Object naming convention for bearings on abutments

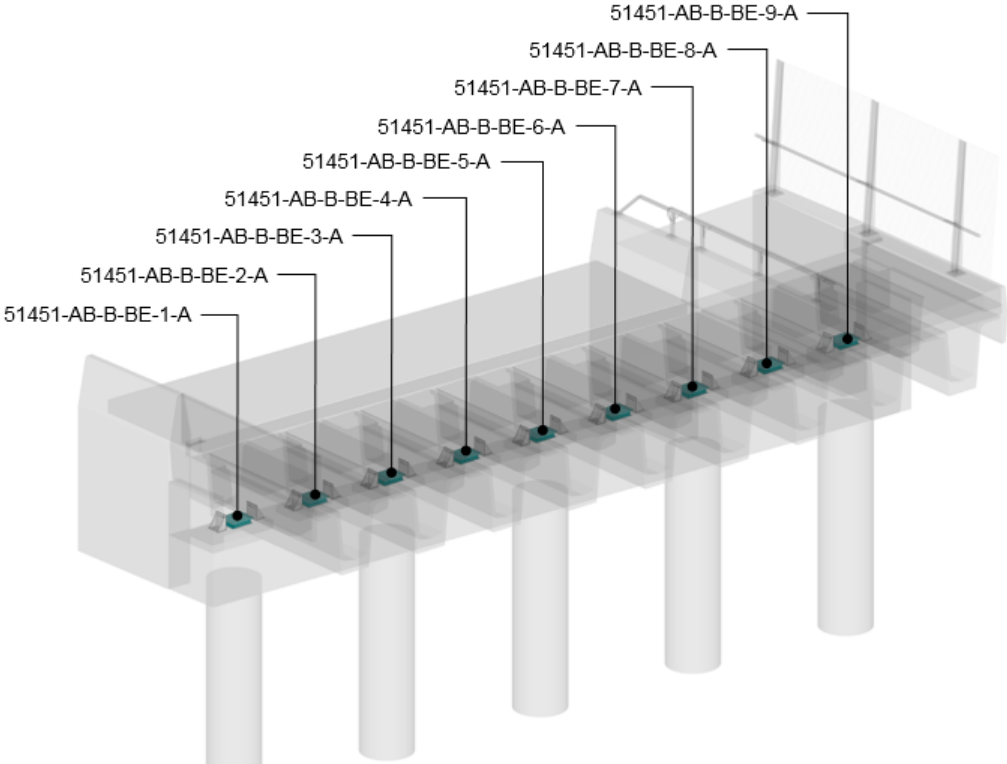
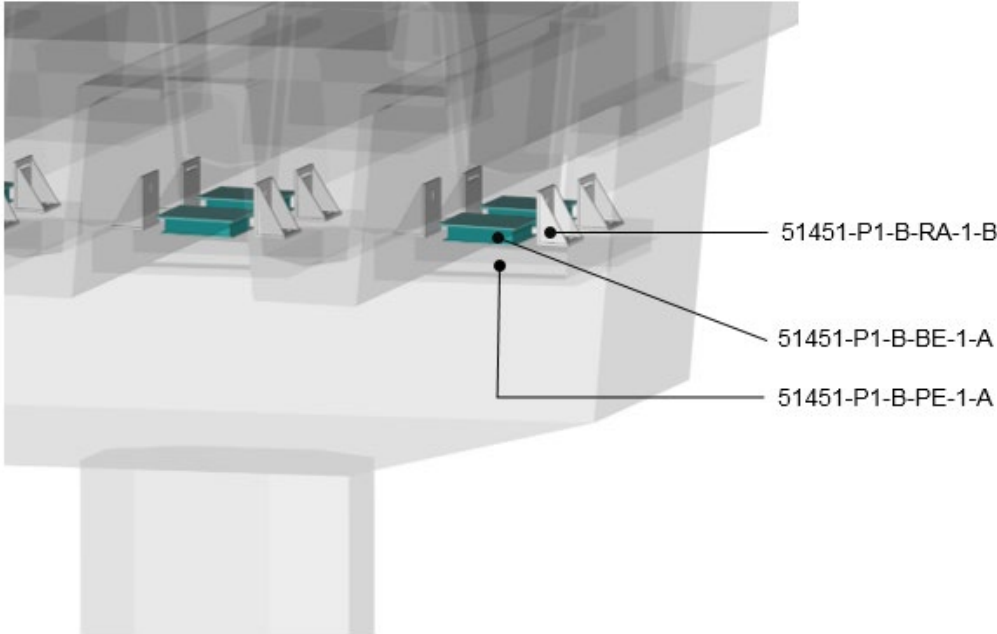

Figure 5.2.2.4(c) – Naming convention for bearing objects



5.2.3 Superstructure

5.2.3.1 Girders

Figure 5.2.3.1(a), Figure 5.2.3.1(b) and Figure 5.2.3.1(c) show the naming convention for girder objects in the bridge BIM model. The naming convention adopts the following methodology:

- Girders (deck units, concrete girders, steel girders, and timber girders) are numbered sequentially left-to-right along a section through the respective span looking 'up chainage' (increasing chainage).
- Transverse stressing bars for deck unit bridges are to be numbered sequentially along the span with increasing chainage.
- Concrete diaphragms and cross girders are to be numbered sequentially along the span with increasing chainage.
- The 'type' identifier distinguishes between different varieties of the girder objects. For example, precast concrete girders, distinguishing outside and insider girders.

Figure 5.2.3.1(a) – Naming convention for deck unit objects

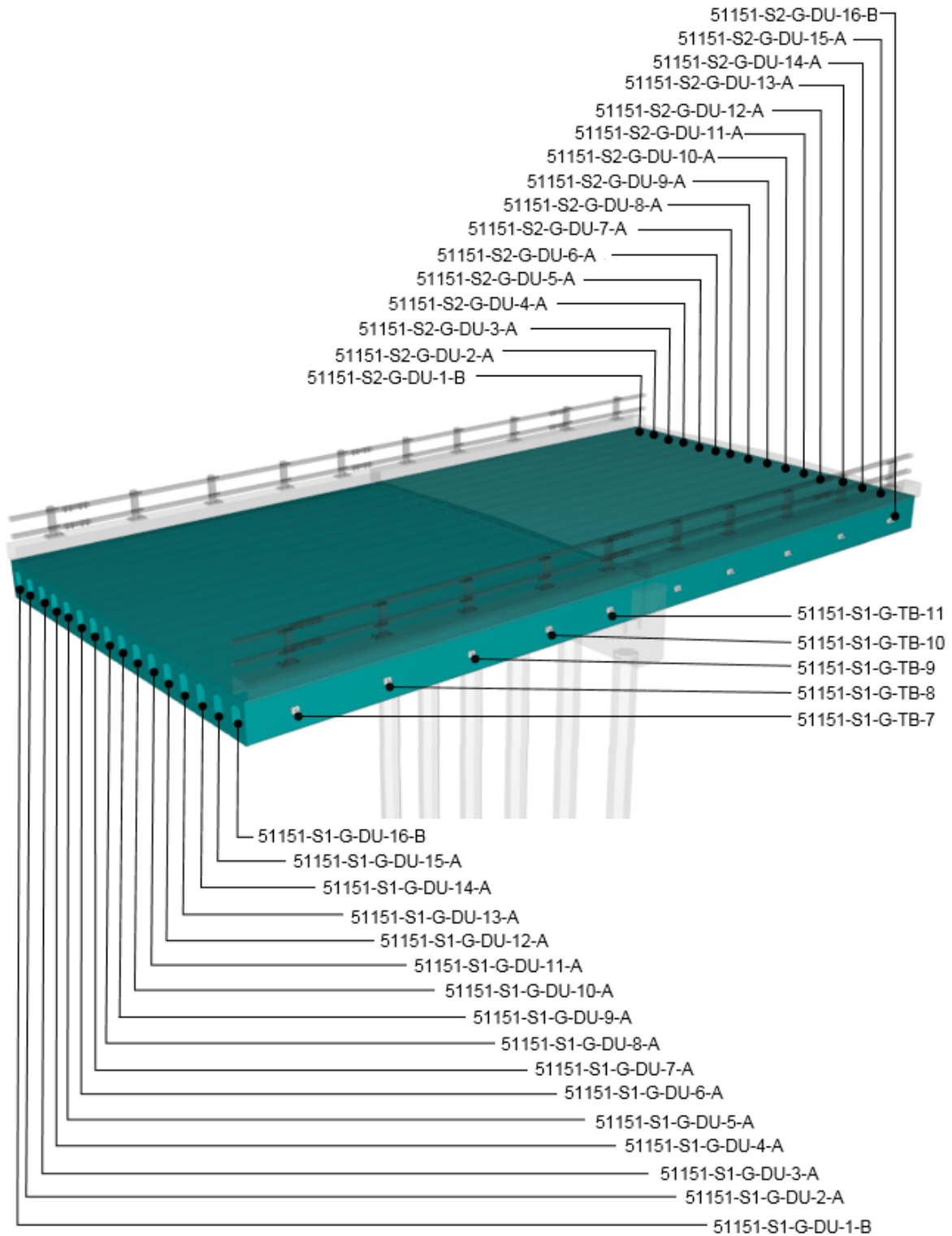

Figure 5.2.3.1(b) – Naming convention for concrete girder (Super-T) objects

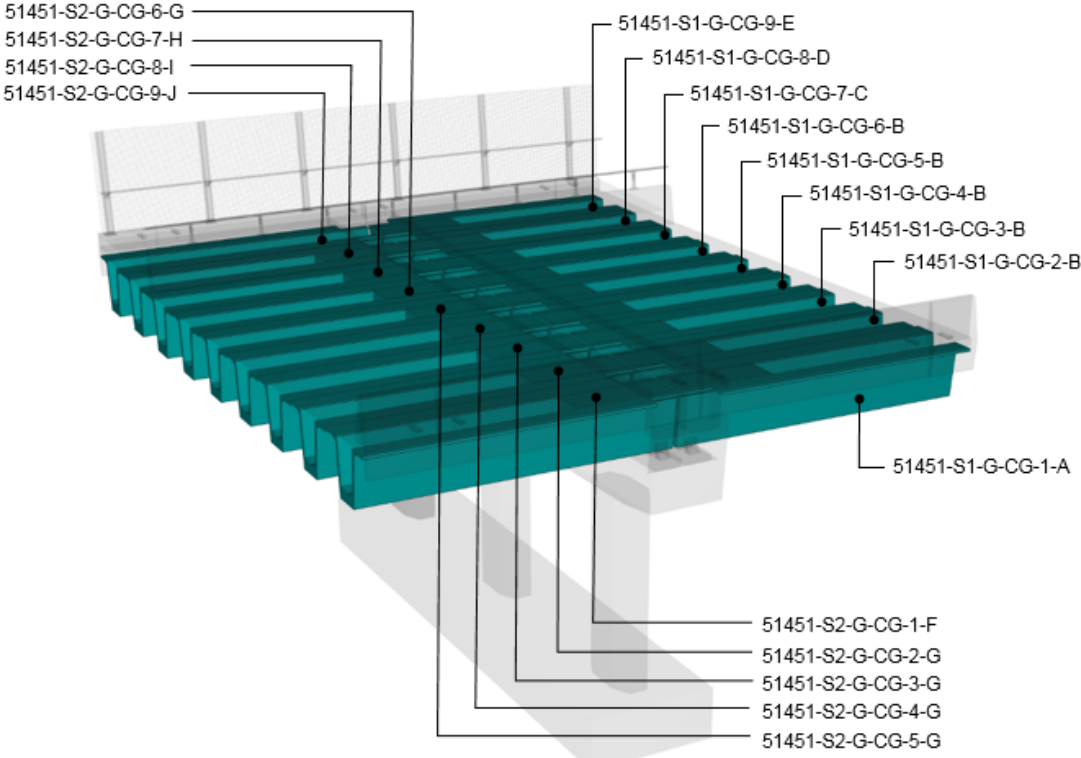
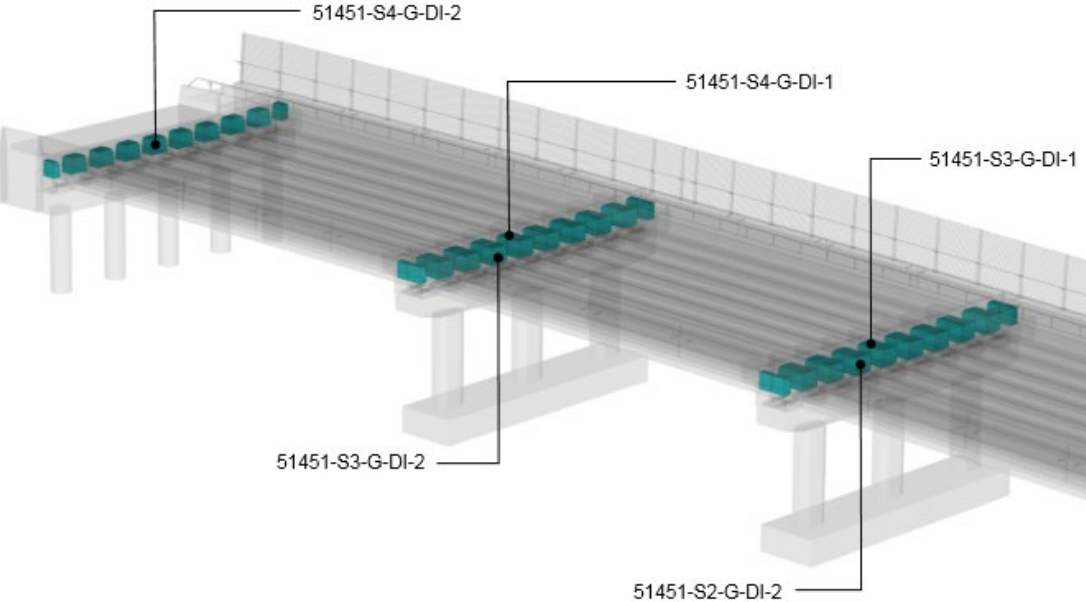

Figure 5.2.3.1(c) – Naming convention for concrete diaphragm objects



5.2.3.2 Bridge deck

Figure 5.2.3.2(a) and Figure 5.2.3.2(b) show the naming convention for deck objects in the bridge BIM model. The naming convention adopts the following methodology:

- Cast insitu decks are identified and numbered at the respective span location. Infill pours, for link slabs / spans over continuous joints may be separated from the main span cast insitu deck object, if elected.
- Cast insitu kerbs are numbered sequentially left-to-right along a section through the respective span looking 'up chainage' (increasing chainage). Cast insitu kerbs objects are separated and defined for each span.
- Shared paths / footways are identified and numbered at the respective span location. Where there are multiple shared paths / footways on a bridge (for example, either side of the bridge), the objects are numbered sequentially left-to-right along a section through the respective span looking 'up chainage' (increasing chainage).
- Fascia panels are identified at the respective span location.
 - The objects are numbered sequentially along the entire length of one side, followed by the other side of the structure with the number sequence continued.
 - Fascia panels on the left-hand-side (section through the bridge looking 'up chainage') are numbered first.
 - The 'type' identifier distinguishes between different varieties. For example, different lengths, and geometric arrangements of precast panels.
- The Deck Wearing Surface (DWS) object can be developed, identified and numbered in either of the following:
 - as a complete object for the entire length of the bridge, or
 - as separate objects on the respective spans, as per cast insitu deck objects.

Figure 5.2.3.2(a) – Naming convention for deck objects of a transversely stressed bridge

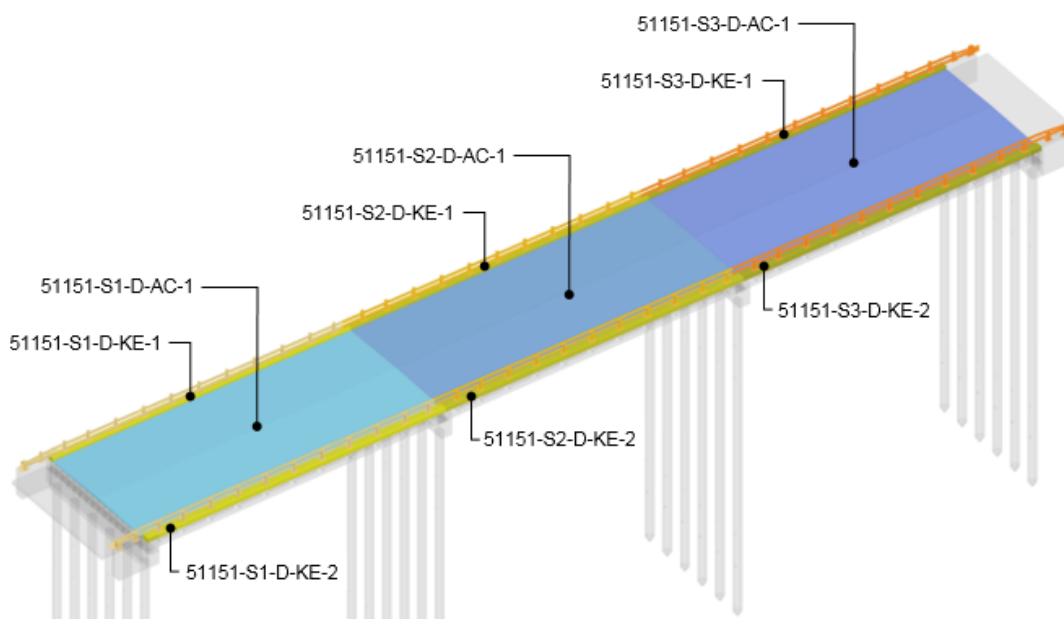
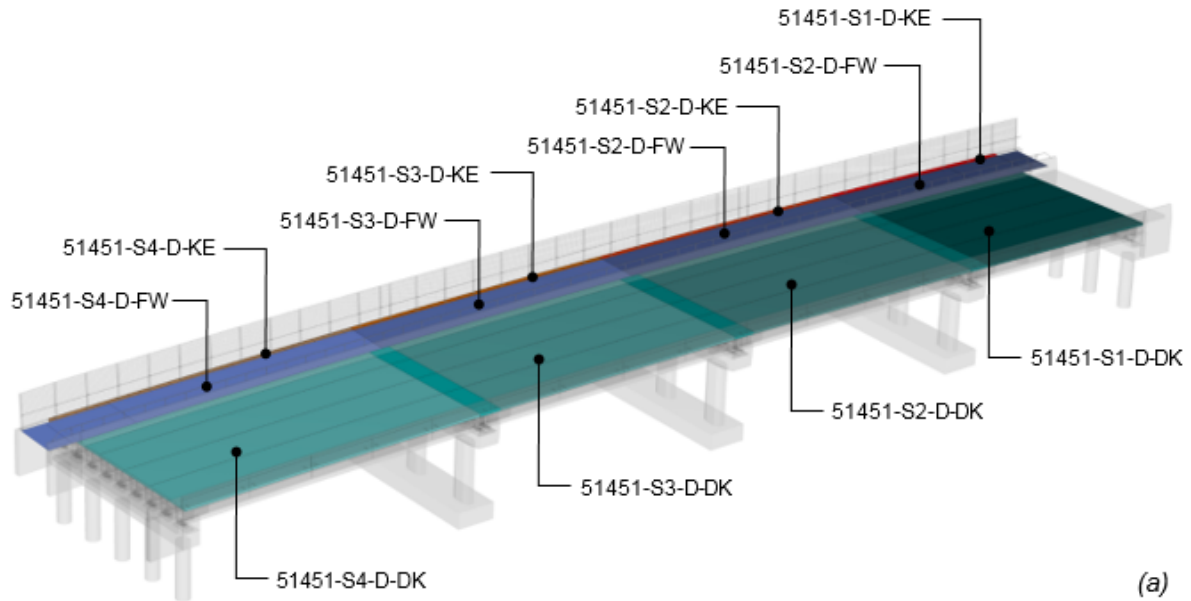

Figure 5.2.3.2(b) – Naming convention for bridge deck objects

5.2.3.3 Bridge traffic barriers

Figure 5.2.3.3 shows the naming convention for the group of bridge traffic barriers objects in the bridge BIM model. The naming convention adopts the following methodology:

- Steel post and rail type, concrete parapet type, balustrade, safety rail, and anti-throw screen objects are:
 - Identified at the respective span location.
 - Numbered sequentially left-to-right along a section through the respective span looking 'up chainage' (increasing chainage), and the object shall encompass the entire length of the span.
 - All objects in the traffic barrier assembly are to be grouped as one object on export to .ifc. This enables the department to format the data assigned to the traffic barrier for import into asset management systems.
 - For steel components (steel post and rail type barrier, balustrade, safety rail, and anti-throw screens) the object can encompass all the components including, posts, rails, and hold-down bolts.
 - For concrete barrier components, the object shall be separated from the fascia panel object in the bridge BIM model.
- Guard rail (and thrie beam) bridge barriers shall be identified and numbered in a similar manner to a steel post and rail type barrier.

Figure 5.2.3.3 – Naming convention for bridge barrier objects

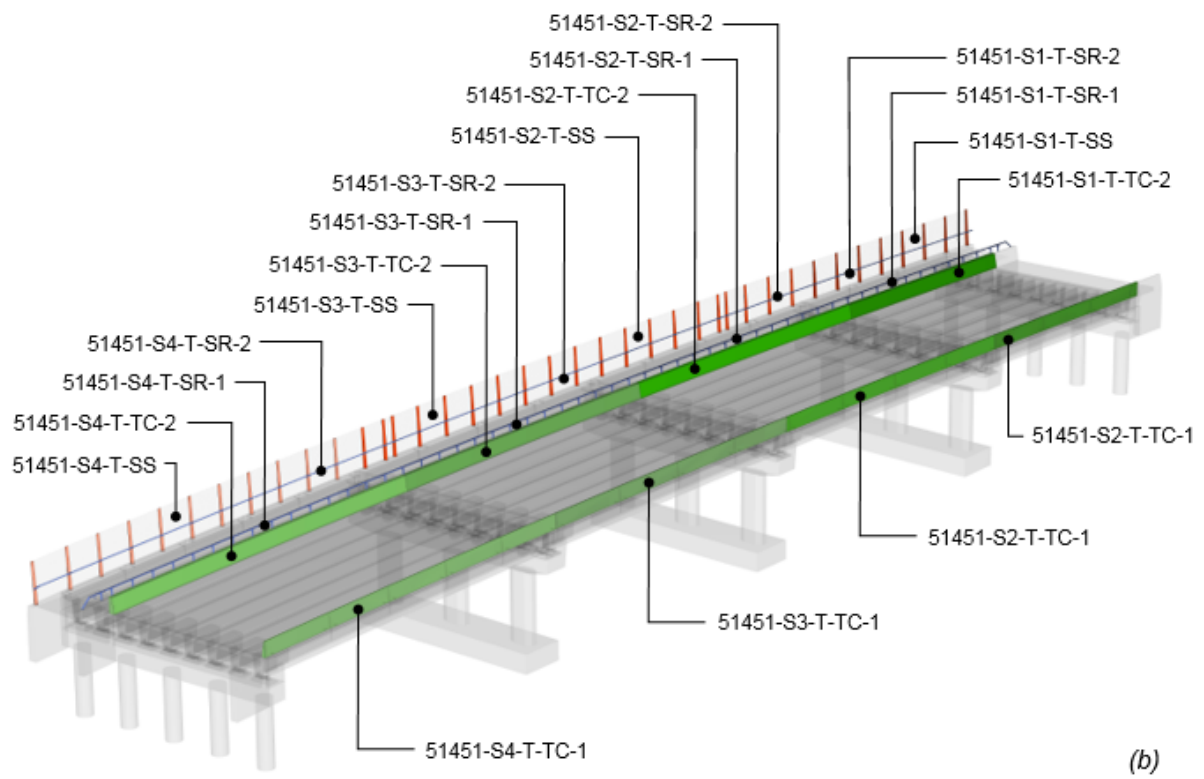
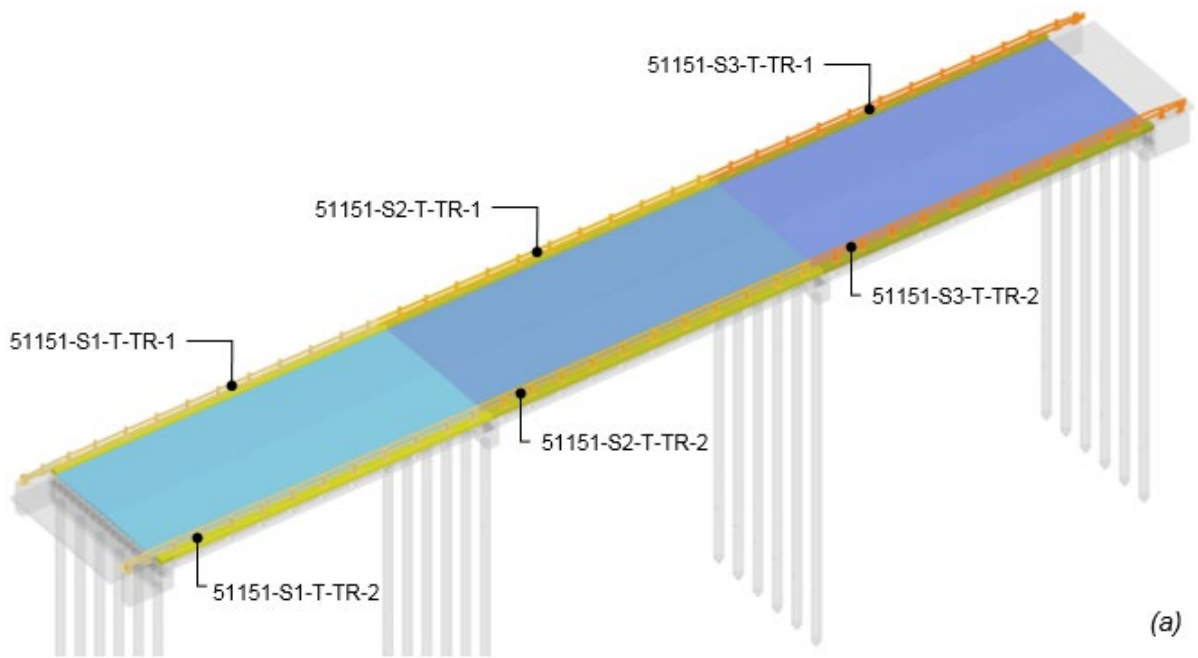

5.2.4 Miscellaneous items

Figure 5.2.4 shows the naming convention for some miscellaneous objects (expansion joints) in the bridge BIM model. The naming convention adopts the following methodology:

- Joints and expansion joints shall be identified at the respective abutment or pier.
- Light poles can be identified at either the abutment / pier or along a span. These objects shall be numbered in a manner that reflects the schedules on the project specific drawings.
- Drainage pipes are identified and numbered along spans, and piers with the object boundary usually defined by change in direction or material. For example, along a span as one object and down a pier as another object.
- PUP conduits that are cast in, or hanging from the structure, shall be numbered sequentially reflecting the details on the project specific drawings, and
- Other miscellaneous items shall be identified and numbered in a manner reflecting the details on the project specific drawings, and enables the attachment of As Constructed and fabrication records in a logical manner.

Figure 5.2.4 – Naming convention for expansion joint objects

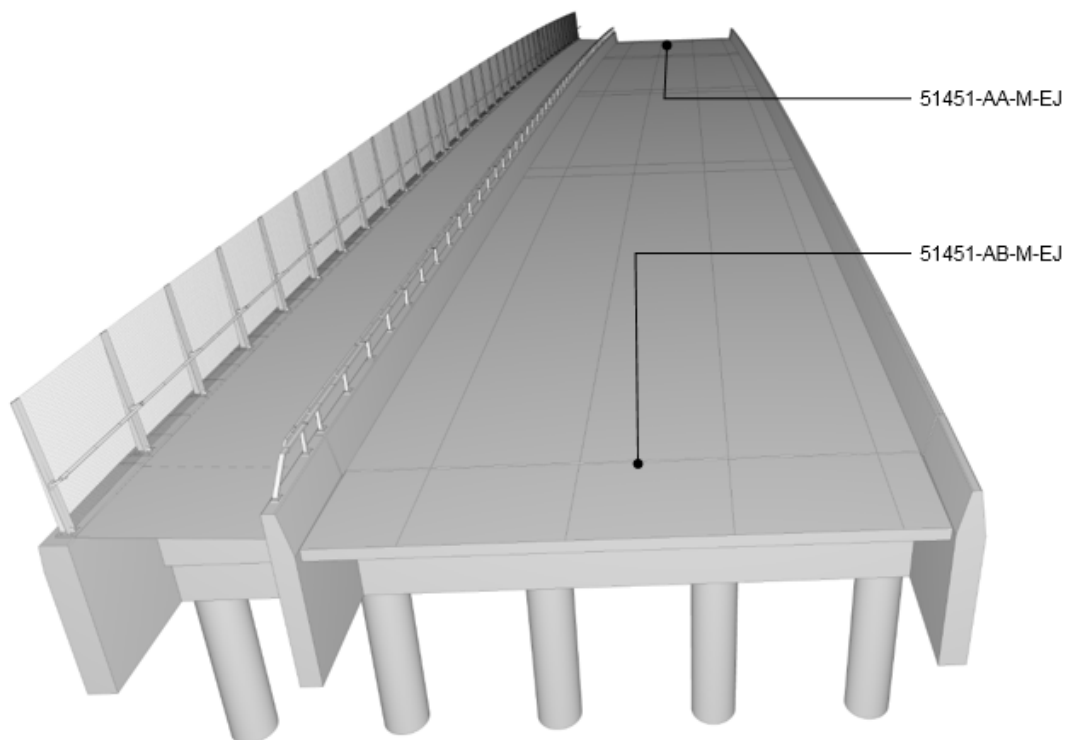

5.3 Bridge BIM model interface with the Bridge Information System

Transport and Main Road's intends to integrate the bridge BIM model into the department's established Bridge Asset Management System (BAMS) and Bridge Information System (BIS), in order to increase the efficiency of managing Queensland's bridge assets. Bridge BIM models integrated with BIS will increase the accessibility of bridge inventory, As Constructed records, asset condition, load capacity, and inspection history for bridge assets.

In order to facilitate this integration with the department's BIS, objects of the bridge BIM model shall be assigned an .ifc Class and .ifc Type as outlined in Table 5.3.

Table 5.3 – Bridge BIM model object .ifc assignment

Group	Group code	.ifc Class	.ifc Type
Abutments	A	IfcSlab	IfcSlabType
Piers	P	IfcMember	IfcMemberType
Foundations	F	IfcPile	N/A
Bridge Traffic barriers	T	IfcRailing	IfcRailingType
Bearings	B	IfcPlate	IfcPlateType
Decks	D	IfcCovering	IfcCoveringType
Girders	G	IfcBeam	IfcBeamType
Miscellaneous	M	IfcBuildingElementProxy	IfcBuildingElementProxyType

Note:

1. For information on .ifc class and type assignment to Revit parameters, refer to [how to notes for Transport and Main Roads Revit to IFC Export pack](#).

6 Bridge BIM model Level of Development for design development phases

The required Level of Development for the bridge BIM model for each design development phase is outlined in Table 6.

Table 6 – Bridge BIM model required Level of Development

Design Development Phase	Required Bridge BIM model Level of Development
50% Design Development	<ul style="list-style-type: none"> • General arrangement including: <ul style="list-style-type: none"> – span arrangement – articulation – selection of substructure type, including preliminary founding levels – selection of superstructure type, including number of deck units / girders – general abutment and pier headstocks • Ground profile • Approach embankments / cuttings • Road under the structure for overpass bridges • All bridge object concrete geometric and design details • Deck units, girders • Bearings details, bearing support systems and restraint blocks • Set out, and modelling of bridge traffic barriers, and kerbs • Interfacing with road design and other technical disciplines, including ITS, drainage etc. including deck wearing surfaces, drainage penetrations etc. • Abutment and abutment protection details, RSS walls • Demonstration of development of TMR custom property sets as per <i>TMR object attributes for bridges</i>.
85% Design Development	<ul style="list-style-type: none"> • All fabricated steel work, balustrades, safety screens, and cast in place elements including hold down bolts • Design and asset management property sets and attributes applied to all bridge objects • Full BIM object code assigned to all relevant bridge objects
100% Design Development	<ul style="list-style-type: none"> • Inclusion of final review details and required adjustments • All details required to undertake the final set out and construction of the bridge • All property sets and attributes assigned to all bridge elements as per <i>TMR object attributes for bridges</i>. • RPEQ Certification Statement that the design model is produced accurately and is ready for handover for survey setout. The data contained in the model is to be read in conjunction with the information supplied on the design drawings. • RPEQ Certification attribute value completed as per <i>TMR object attributes for bridges</i>.

Construction Phase	Required Bridge BIM model Level of Development
Certified As Constructed (CAC)	<ul style="list-style-type: none"> • Object based model that presents all bridge components constructed and adheres to MRTS56 <i>Construction Surveying</i>. • Delivered in .ifc format containing As Constructed property sets as per <i>TMR object attributes for bridges</i> • The contractor shall provide certification that the bridge BIM model is an accurate representation of the constructed bridge, in accordance with the As Constructed drawing requirements of MRTS50 <i>Specific Quality System Requirements</i>. • The Administrator must have documentation to prove As Constructed details are true and correct, and shall issue a statement of conformity that the bridge BIM model is accurate

7 Bridge BIM model attributes

The bridge BIM model shall be developed to allow the incorporation and attachment of design, As Constructed, and asset management information and records to each bridge object. The minimum information required to be attributed to a bridge object is outlined within this section. The design consultant shall prepare procedures and demonstrate the capability to attach the relevant design and asset management information to the bridge BIM model, in the consultant's BIM execution plan. The contractor shall prepare procedures and demonstrate the capability to attach the relevant As Constructed information to the bridge BIM model in the contractor's BIM execution plan.

7.1 Transport and Main Road's bridge object property sets

Objects within the bridge BIM model shall be developed to have the following property sets:

- Design information (TMR)
- As Constructed information (TMR)
- Asset management information (TMR) (Refer to *Structures Inspection Manual (SIM)*)

The property sets shall be created and displayed as separate tabs in the properties window within a model file viewer, for selected objects (as shown in Figure 7.1). The property sets are defined in the *TMR object attributes for bridges*, published on the departmental website. For asset management attribute values, refer to the *Structures Inspection Manual (SIM) Part 3: Procedures* and Appendix B: *Standard Component Schedule*. For objects not listed in the *TMR object attributes for bridges*, the design consultant or contractor shall prepare and submit attribute schedules for these objects to suit the needs of the project, as part of their BIM execution plan.

Figure 7.1 – Example of attribute properties for a concrete girder

As-Con Information		Asset Management Information			BaseQuantities	
Identification	Location	Quantities	Material	Relations	Classification	Hyperlinks
BaseQuantities		Design Information		Manufacture Information		
Property				Value		
BIM Component Code				78689-S5-G-CG-01-B		
Cast in Anchor/Hoop				PHILIPP Lifting Hoop : Part No. 442470		
Cast in Bearing Attachment Plate				20 Thick Steel Plate		
Characteristic Compressive Strength (MPa) - Design				50		
Characteristic Minimum Cover				40		
Concrete Class				S50/20		
Concrete Compressive Strength at Transfer (MPa) - Design				40		
Element Depth				1525		
Element Length				27951		
Exposure Classification				B2		
Hog 100 Days - Design				78		
Hog 30 Days - Design				60		
Hog Transfer - Design				28		
Mass (T)				60		
Nominal Length of End Blocks				2726		
Nominal Top Flange Width				1954		
Number of 5m Voids				4		
Number of Small Voids				1		
TMR Specification				MRTS73		
Typical Strand Profile				50		

Appendix A – BIM Schedule example

Component			Component Identification							
Category	Description		BIS structure ID	Location	Group ID	Component ID	Number	Type	Full Code	Comments
	Group	Component								
Bridge	Foundation	Precast Pile	51151	AA	F	PP	1		51151-AA-F-PP-1	
Bridge	Foundation	Precast Pile	51151	AA	F	PP	2		51151-AA-F-PP-2	
Bridge	Foundation	Precast Pile	51151	AA	F	PP	3		51151-AA-F-PP-3	
Bridge	Foundation	Precast Pile	51151	AA	F	PP	4		51151-AA-F-PP-4	
Bridge	Foundation	Precast Pile	51151	AA	F	PP	5		51151-AA-F-PP-5	
Bridge	Foundation	Precast Pile	51151	AA	F	PP	6		51151-AA-F-PP-6	
Bridge	Foundation	Precast Pile	51151	P1	F	PP	1		51151-P1-F-PP-1	
Bridge	Foundation	Precast Pile	51151	P1	F	PP	2		51151-P1-F-PP-2	
Bridge	Foundation	Precast Pile	51151	P1	F	PP	3		51151-P1-F-PP-3	
Bridge	Foundation	Precast Pile	51151	P1	F	PP	4		51151-P1-F-PP-4	
Bridge	Foundation	Precast Pile	51151	P1	F	PP	5		51151-P1-F-PP-5	
Bridge	Foundation	Precast Pile	51151	P1	F	PP	6		51151-P1-F-PP-6	
Bridge	Foundation	Precast Pile	51151	P2	F	PP	1		51151-P2-F-PP-1	
Bridge	Foundation	Precast Pile	51151	P2	F	PP	2		51151-P2-F-PP-2	
Bridge	Foundation	Precast Pile	51151	P2	F	PP	3		51151-P2-F-PP-3	
Bridge	Foundation	Precast Pile	51151	P2	F	PP	4		51151-P2-F-PP-4	
Bridge	Foundation	Precast Pile	51151	P2	F	PP	5		51151-P2-F-PP-5	
Bridge	Foundation	Precast Pile	51151	P2	F	PP	6		51151-P2-F-PP-6	
Bridge	Foundation	Precast Pile	51151	AB	F	PP	1		51151-AB-F-PP-1	
Bridge	Foundation	Precast Pile	51151	AB	F	PP	2		51151-AB-F-PP-2	

Component			Component Identification							
Category	Description		BIS structure ID	Location	Group ID	Component ID	Number	Type	Full Code	Comments
	Group	Component								
Bridge	Foundation	Precast Pile	51151	AB	F	PP	3		51151-AB-F-PP-3	
Bridge	Foundation	Precast Pile	51151	AB	F	PP	4		51151-AB-F-PP-4	
Bridge	Foundation	Precast Pile	51151	AB	F	PP	5		51151-AB-F-PP-5	
Bridge	Foundation	Precast Pile	51151	AB	F	PP	6		51151-AB-F-PP-6	
Bridge	Abutment	Headstock	51151	AA	A	HS			51151-AA-A-HS	
Bridge	Abutment	Wing Wall	51151	AA	A	WW	1		51151-AA-A-WW-1	
Bridge	Abutment	Wing Wall	51151	AA	A	WW	2		51151-AA-A-WW-2	
Bridge	Abutment	Relieving Slab	51151	AA	A	RS			51151-AA-A-RS	
Bridge	Abutment	Abutment Protection	51151	AA	A	AP			51151-AA-A-AP	
Bridge	Abutment	Headstock	51151	AB	A	HS			51151-AB-A-HS	
Bridge	Abutment	Wing Wall	51151	AB	A	WW	1		51151-AB-A-WW-1	
Bridge	Abutment	Wing Wall	51151	AB	A	WW	2		51151-AB-A-WW-2	
Bridge	Abutment	Relieving Slab	51151	AB	A	RS			51151-AB-A-RS	
Bridge	Abutment	Abutment Protection	51151	AB	A	AP			51151-AB-A-AP	
Bridge	Pier	Headstock	51151	P1	P	HS			51151-P1-P-HS	
Bridge	Pier	Headstock	51151	P2	P	HS			51151-P2-P-HS	
Bridge	Girders	Deck Units	51151	S1	G	DU	1	B	51151-S1-G-DU-1-B	
Bridge	Girders	Deck Units	51151	S1	G	DU	2	A	51151-S1-G-DU-2-A	
Bridge	Girders	Deck Units	51151	S1	G	DU	3	A	51151-S1-G-DU-3-A	
Bridge	Girders	Deck Units	51151	S1	G	DU	4	A	51151-S1-G-DU-4-A	

Component			Component Identification							
Category	Description		BIS structure ID	Location	Group ID	Component ID	Number	Type	Full Code	Comments
	Group	Component								
Bridge	Girders	Deck Units	51151	S1	G	DU	5	A	51151-S1-G-DU-5-A	
Bridge	Girders	Deck Units	51151	S1	G	DU	6	A	51151-S1-G-DU-6-A	
Bridge	Girders	Deck Units	51151	S1	G	DU	7	A	51151-S1-G-DU-7-A	
Bridge	Girders	Deck Units	51151	S1	G	DU	8	A	51151-S1-G-DU-8-A	
Bridge	Girders	Deck Units	51151	S1	G	DU	9	A	51151-S1-G-DU-9-A	
Bridge	Girders	Deck Units	51151	S1	G	DU	10	A	51151-S1-G-DU-10-A	
Bridge	Girders	Deck Units	51151	S1	G	DU	11	A	51151-S1-G-DU-11-A	
Bridge	Girders	Deck Units	51151	S1	G	DU	12	A	51151-S1-G-DU-12-A	
Bridge	Girders	Deck Units	51151	S1	G	DU	13	A	51151-S1-G-DU-13-A	
Bridge	Girders	Deck Units	51151	S1	G	DU	14	A	51151-S1-G-DU-14-A	
Bridge	Girders	Deck Units	51151	S1	G	DU	15	A	51151-S1-G-DU-15-A	
Bridge	Girders	Deck Units	51151	S1	G	DU	16	B	51151-S1-G-DU-16-B	
Bridge	Girders	Deck Units	51151	S2	G	DU	1	B	51151-S2-G-DU-1-B	
Bridge	Girders	Deck Units	51151	S2	G	DU	2	A	51151-S2-G-DU-2-A	
Bridge	Girders	Deck Units	51151	S2	G	DU	3	A	51151-S2-G-DU-3-A	
Bridge	Girders	Deck Units	51151	S2	G	DU	4	A	51151-S2-G-DU-4-A	
Bridge	Girders	Deck Units	51151	S2	G	DU	5	A	51151-S2-G-DU-5-A	
Bridge	Girders	Deck Units	51151	S2	G	DU	6	A	51151-S2-G-DU-6-A	
Bridge	Girders	Deck Units	51151	S2	G	DU	7	A	51151-S2-G-DU-7-A	
Bridge	Girders	Deck Units	51151	S2	G	DU	8	A	51151-S2-G-DU-8-A	
Bridge	Girders	Deck Units	51151	S2	G	DU	9	A	51151-S2-G-DU-9-A	

Component			Component Identification							
Category	Description		BIS structure ID	Location	Group ID	Component ID	Number	Type	Full Code	Comments
	Group	Component								
Bridge	Girders	Deck Units	51151	S2	G	DU	10	A	51151-S2-G-DU-10-A	
Bridge	Girders	Deck Units	51151	S2	G	DU	11	A	51151-S2-G-DU-11-A	
Bridge	Girders	Deck Units	51151	S2	G	DU	12	A	51151-S2-G-DU-12-A	
Bridge	Girders	Deck Units	51151	S2	G	DU	13	A	51151-S2-G-DU-13-A	
Bridge	Girders	Deck Units	51151	S2	G	DU	14	A	51151-S2-G-DU-14-A	
Bridge	Girders	Deck Units	51151	S2	G	DU	15	A	51151-S2-G-DU-15-A	
Bridge	Girders	Deck Units	51151	S2	G	DU	16	B	51151-S2-G-DU-16-B	
Bridge	Girders	Deck Units	51151	S3	G	DU	1	B	51151-S3-G-DU-1-B	
Bridge	Girders	Deck Units	51151	S3	G	DU	2	A	51151-S3-G-DU-2-A	
Bridge	Girders	Deck Units	51151	S3	G	DU	3	A	51151-S3-G-DU-3-A	
Bridge	Girders	Deck Units	51151	S3	G	DU	4	A	51151-S3-G-DU-4-A	
Bridge	Girders	Deck Units	51151	S3	G	DU	5	A	51151-S3-G-DU-5-A	
Bridge	Girders	Deck Units	51151	S3	G	DU	6	A	51151-S3-G-DU-6-A	
Bridge	Girders	Deck Units	51151	S3	G	DU	7	A	51151-S3-G-DU-7-A	
Bridge	Girders	Deck Units	51151	S3	G	DU	8	A	51151-S3-G-DU-8-A	
Bridge	Girders	Deck Units	51151	S3	G	DU	9	A	51151-S3-G-DU-9-A	
Bridge	Girders	Deck Units	51151	S3	G	DU	10	A	51151-S3-G-DU-10-A	
Bridge	Girders	Deck Units	51151	S3	G	DU	11	A	51151-S3-G-DU-11-A	
Bridge	Girders	Deck Units	51151	S3	G	DU	12	A	51151-S3-G-DU-12-A	
Bridge	Girders	Deck Units	51151	S3	G	DU	13	A	51151-S3-G-DU-13-A	
Bridge	Girders	Deck Units	51151	S3	G	DU	14	A	51151-S3-G-DU-14-A	

Component			Component Identification							
Category	Description		BIS structure ID	Location	Group ID	Component ID	Number	Type	Full Code	Comments
	Group	Component								
Bridge	Girders	Deck Units	51151	S3	G	DU	15	A	51151-S3-G-DU-15-A	
Bridge	Girders	Deck Units	51151	S3	G	DU	16	B	51151-S3-G-DU-16-B	
Bridge	Girders	Transverse Bars	51151	S1	G	TB	1		51151-S1-G-TB-1	
Bridge	Girders	Transverse Bars	51151	S1	G	TB	2		51151-S1-G-TB-2	
Bridge	Girders	Transverse Bars	51151	S1	G	TB	3		51151-S1-G-TB-3	
Bridge	Girders	Transverse Bars	51151	S1	G	TB	4		51151-S1-G-TB-4	
Bridge	Girders	Transverse Bars	51151	S1	G	TB	5		51151-S1-G-TB-5	
Bridge	Girders	Transverse Bars	51151	S1	G	TB	6		51151-S1-G-TB-6	
Bridge	Girders	Transverse Bars	51151	S1	G	TB	7		51151-S1-G-TB-7	
Bridge	Girders	Transverse Bars	51151	S1	G	TB	8		51151-S1-G-TB-8	
Bridge	Girders	Transverse Bars	51151	S1	G	TB	9		51151-S1-G-TB-9	
Bridge	Girders	Transverse Bars	51151	S1	G	TB	10		51151-S1-G-TB-10	
Bridge	Girders	Transverse Bars	51151	S1	G	TB	11		51151-S1-G-TB-11	
Bridge	Girders	Transverse Bars	51151	S2	G	TB	1		51151-S2-G-TB-1	

Component			Component Identification							
Category	Description		BIS structure ID	Location	Group ID	Component ID	Number	Type	Full Code	Comments
	Group	Component								
Bridge	Girders	Transverse Bars	51151	S2	G	TB	2		51151-S2-G-TB-2	
Bridge	Girders	Transverse Bars	51151	S2	G	TB	3		51151-S2-G-TB-3	
Bridge	Girders	Transverse Bars	51151	S2	G	TB	4		51151-S2-G-TB-4	
Bridge	Girders	Transverse Bars	51151	S2	G	TB	5		51151-S2-G-TB-5	
Bridge	Girders	Transverse Bars	51151	S2	G	TB	6		51151-S2-G-TB-6	
Bridge	Girders	Transverse Bars	51151	S2	G	TB	7		51151-S2-G-TB-7	
Bridge	Girders	Transverse Bars	51151	S2	G	TB	8		51151-S2-G-TB-8	
Bridge	Girders	Transverse Bars	51151	S2	G	TB	9		51151-S2-G-TB-9	
Bridge	Girders	Transverse Bars	51151	S2	G	TB	10		51151-S2-G-TB-10	
Bridge	Girders	Transverse Bars	51151	S2	G	TB	11		51151-S2-G-TB-11	
Bridge	Girders	Transverse Bars	51151	S3	G	TB	1		51151-S3-G-TB-1	
Bridge	Girders	Transverse Bars	51151	S3	G	TB	2		51151-S3-G-TB-2	
Bridge	Girders	Transverse Bars	51151	S3	G	TB	3		51151-S3-G-TB-3	

Component			Component Identification							
Category	Description		BIS structure ID	Location	Group ID	Component ID	Number	Type	Full Code	Comments
	Group	Component								
Bridge	Girders	Transverse Bars	51151	S3	G	TB	4		51151-S3-G-TB-4	
Bridge	Girders	Transverse Bars	51151	S3	G	TB	5		51151-S3-G-TB-5	
Bridge	Girders	Transverse Bars	51151	S3	G	TB	6		51151-S3-G-TB-6	
Bridge	Girders	Transverse Bars	51151	S3	G	TB	7		51151-S3-G-TB-7	
Bridge	Girders	Transverse Bars	51151	S3	G	TB	8		51151-S3-G-TB-8	
Bridge	Girders	Transverse Bars	51151	S3	G	TB	9		51151-S3-G-TB-9	
Bridge	Girders	Transverse Bars	51151	S3	G	TB	10		51151-S3-G-TB-10	
Bridge	Girders	Transverse Bars	51151	S3	G	TB	11		51151-S3-G-TB-11	
Bridge	Deck	Cast Insitu Kerb	51151	S1	D	KE	1		51151-S1-D-KE-1	1 is left looking abut a to b
Bridge	Deck	Cast Insitu Kerb	51151	S1	D	KE	2		51151-S1-D-KE-2	2 is right looking abut a to b
Bridge	Deck	Cast Insitu Kerb	51151	S2	D	KE	1		51151-S2-D-KE-1	1 is left looking abut a to b
Bridge	Deck	Cast Insitu Kerb	51151	S2	D	KE	2		51151-S2-D-KE-2	2 is right looking abut a to b
Bridge	Deck	Cast Insitu Kerb	51151	S3	D	KE	1		51151-S3-D-KE-1	1 is left looking abut a to b
Bridge	Deck	Cast Insitu Kerb	51151	S3	D	KE	2		51151-S3-D-KE-2	2 is right looking abut a to b
Bridge	Deck	Deck Wearing Surface	51151	S1	D	AC			51151-S1-D-AC	

Component			Component Identification							
Category	Description		BIS structure ID	Location	Group ID	Component ID	Number	Type	Full Code	Comments
	Group	Component								
Bridge	Deck	Deck Wearing Surface	51151	S2	D	AC			51151-S2-D-AC	
Bridge	Deck	Deck Wearing Surface	51151	S3	D	AC			51151-S3-D-AC	
Bridge	Bridge Traffic Barriers	Steel Post and Rail Type	51151	S1	T	TR	1		51151-S1-T-TR-1	1 is left looking about a to b
Bridge	Bridge Traffic Barriers	Steel Post and Rail Type	51151	S1	T	TR	2		51151-S1-T-TR-2	2 is right looking about a to b
Bridge	Bridge Traffic Barriers	Steel Post and Rail Type	51151	S2	T	TR	1		51151-S2-T-TR-1	1 is left looking about a to b
Bridge	Bridge Traffic Barriers	Steel Post and Rail Type	51151	S2	T	TR	2		51151-S2-T-TR-2	2 is right looking about a to b
Bridge	Bridge Traffic Barriers	Steel Post and Rail Type	51151	S3	T	TR	1		51151-S3-T-TR-1	1 is left looking about a to b
Bridge	Bridge Traffic Barriers	Steel Post and Rail Type	51151	S3	T	TR	2		51151-S3-T-TR-2	2 is right looking about a to b

